



**CITY OF YPSILANTI  
REGULAR COUNCIL MEETING  
Tuesday, April 21, 2026 @ 7:00 PM  
Council Chambers  
One South Huron, Ypsilanti, MI 48197  
[Launch Meeting - Zoom](#)**

---

**I. CALL TO ORDER**

**II. ROLL CALL**

**III. A MOMENT TO CENTER AND FOCUS**

**IV. AGENDA APPROVAL**

**V. PUBLIC COMMENT - 60 MINUTES TOTAL (3 MINUTES/EACH SPEAKER)**

**VI. PRESENTATIONS**

- A. Proclamation for story time on the move
- B. Roads Presentation

**VII. ORDINANCES FIRST READING**

- A. Ordinance No. 1461 - Entitled "An ordinance to impose an emergency moratorium on issuance of new zoning permits for data centers in the City of Ypsilanti for 60 days."  
Public Hearing Resolution No. 2026-092, close the public hearing.  
Resolution No. 2026-093, determination
- B. Ordinance No. 1462 - Entitled "Traffic Control Orders Adoption."  
Public Hearing Resolution No. 2026-094, close the public hearing.  
Resolution No. 2026-095, determination

**VIII. RESOLUTIONS/MOTIONS/DISCUSSIONS**

- A. Resolution No. 2026-096, A Resolution to Defund ICE and CBP, Halt Deportation Operations, and Protect Ypsilanti Residents
- B. Resolution No. 2026 - 097, A Resolution Directing \$1,000,000 for a City-Run Community Responder Program and Requesting County Buy-In
- C. Resolution No. 2026-098 Approving the minutes of the regular meeting of April 14, 2026.

- D. Resolution No. 2026-099 Authorizing the Mayor and City Clerk to sign the extension agreement for the Washtenaw County Dispatch Contract, subject to the approval of the City Attorney.
- E. Resolution No. 2026-100 Approving the change order for the Municipal Lots Rehabilitation to Somerset Paving for the total cost of \$214,200, with the DDA reimbursing the City for up to \$204,200, and authorizing the City Manager to sign the change order on the city's behalf.
- F. Resolution No. 2026 - 101 Approving a Building Department Consulting Services Agreement with Carlisle/Wortman Associates, Inc. for building inspection, trade inspection, and commercial plan review services, for the term through April 30, 2028, to be approved as to form by the City Attorney and signed by the City Manager.
- G. Resolution No. 2026 - 102, Approving the MOU with the Depot Town Economic Development Corporation to hold a Cruise Night on Thursday nights between the beginning of June until the end of September for a period of three-years.
- H. Resolution No. 2026-103, A Resolution establishing May 2026 as Low Mow May
- I. Resolution No. 2026-104 Declaring April 28th Workers Memorial Day
- J. Discussion regarding Ypsilanti Townships Resolution No. 2026-08 Requesting that the Ypsilanti Community Utilities Authority Impose an Immediate Moratorium on Services to Data Centers
- K. Discussion Item - Water Street clear cutting
- L. Discussion Item - Gas Leaf Blower Ban

**IX. BOARD AND COMMISSION - LIAISON REPORTS**

- A. Police Advisory Commission
- B. Human Relations Commission
- C. Parks and Arts Commission
- D. Sustainability Commission
- E. Historic District Commission
- F. Planning Commission
- G. Zoning Board of Appeals

**X. LIAISON REPORTS**

- A. SEMCOG Update
- B. Washtenaw Area Transportation Study
- C. Urban County

D. Ypsilanti Downtown Development Authority

E. Friends of Rutherford Pool

**XI. COUNCIL PROPOSED BUSINESS**

**XII. COMMUNICATIONS FROM THE MAYOR**

**XIII. COMMUNICATIONS FROM THE CITY MANAGER**

**XIV. COMMUNICATIONS**

**XV. PUBLIC COMMENT - CONTINUED (3 MINUTES/EACH SPEAKER)**

**XVI. ADJOURNMENT**

A. Please click [here](#) to access the City Council Contact Form. This form can be used to submit any comments/concerns you might have about this agenda.

## Proclamation for Story-Time on the Move

Whereas, the City of Ypsilanti would like to recognize a collaboration between The Ladies Literary Club of Ypsilanti, Washtenaw Promise, and the Ypsilanti High School Athletics Department that exemplifies the spirit of Ypsilanti and our motto of Pride, Diversity, and Heritage;

Whereas, the Ladies Literary Club, under the leadership of Chantel Brown, connected with Washtenaw Promise for Reading Month in March to host an event called, "Story-Time on the Move,"

Whereas, the Ypsilanti High School Athletics Department, under the leadership of Athletic Director Danny Brown, engaged student athletes to serve as reading ambassadors, inspiring and connecting with younger Ypsilanti youth; and

Whereas, the service and leadership of the following students were invaluable to the success of this program:

Caleb Douglas  
Skye Brown  
Amoriá White  
Bintou Kaba  
Destiney Webster

Paris Cameron  
Kameryn Newman-White  
Caleb Smithston  
Maurice Shemwell  
Kyre Reid

Now, Therefore, we extend our deepest gratitude for this intergenerational, educational, and community-centered service to the Ypsilanti community. We celebrate these young leaders and their contributions, which reflect the spirit and very best of what makes Ypsilanti a wonderful place to live, learn, and serve.

Signed by the Mayor of Ypsilanti, Nicole Brown and Ward 3 Representative Desiraé Simmons



Resolution No. 2026-092  
April 21, 2026

**RESOLVED BY THE COUNCIL OF THE CITY OF YPSILANTI:**

That the public hearing for an emergency ordinance entitled "An ordinance to impose an emergency moratorium on issuance of new zoning permits for data centers in the City of Ypsilanti for 60 days." be officially closed.

OFFERED BY: \_\_\_\_\_

SUPPORTED BY: \_\_\_\_\_

YES:            NO:            ABSENT:            VOTE:



**CITY OF YPSILANTI  
NOTICE OF ADOPTED ORDINANCE  
Ordinance No. 1461**

An ordinance to impose an emergency moratorium on issuance of new zoning permits for data centers in the City of Ypsilanti for 60 days.

**1. THE CITY OF YPSILANTI HEREBY ORDAINS** that

Whereas the City of Ypsilanti's Zoning Ordinance does not define data centers or give regulations that pertain to data centers, and;

Whereas City staff requires additional time to study the issues to ensure the preservation of public peace, health, safety and welfare and has requested a moratorium to study the issues, and;

Whereas City Council finds it in the best interest of the City of Ypsilanti for additional staff study on the issues and that a moratorium is required for the public peace, health, safety and welfare,

Now therefore, an emergency moratorium is ordered and ordained on the issuance of new permits data centers in the City of Ypsilanti for 60 days.

**2. Severability.** If any clause, sentence, section, paragraph, or part of this ordinance, or the application thereof to any person, firm, corporation, legal entity, or circumstances, shall be for any reason adjudged by a court of competent jurisdiction to be unconstitutional or invalid, such judgment shall not effect, impair, or invalidate the remainder of this Ordinance and the application of such provision to other persons, firms, corporations, legal entities, or circumstances by such judgment shall be confined in its operation to the clause, sentence, section, paragraph, or part of this Ordinance thereof directly involved in the case or controversy in which such judgment shall have been rendered and to the person, firm, corporation, legal entity, or circumstances then and there involved. It is hereby declared to be the legislative intent of this body that the Ordinance would have been adopted had such invalid or unconstitutional provisions not have been included in this Ordinance.

**3. Repeal.** All other Ordinances inconsistent with the provisions of this Ordinance

are, to the extent of such inconsistencies, hereby repealed.

**4. Savings Clause.** The balance of the Code of Ordinances, City of Ypsilanti, Michigan, except as herein or previously amended, shall remain in full force and effect. The repeal provided herein shall not abrogate or affect any offense or act committed or done, or any penalty or forfeiture incurred, or any pending fee, assessments, litigation, or prosecution of any right established, occurring prior to the effective date hereof.

**5. Copies to be available.** Copies of the Ordinance are available at the office of the city clerk for inspection by, and distribution to, the public during normal office hours.

**6. Publication and Effective Date.** The City Clerk shall cause this Ordinance, or a summary of this Ordinance, to be published according to Section 11.13 of the City Charter. This Ordinance as an emergency ordinance shall become effective immediately.

MADE, PASSED AND ADOPTED BY THE YPSILANTI CITY COUNCIL THIS 21st DAY OF April 2026.

\_\_\_\_\_  
Tracey Broudreau, City Clerk

Attest

I do hereby confirm that the above Emergency Ordinance No. was published according to Section 11.13 of the City Charter on the 21st DAY OF April.

\_\_\_\_\_  
Tracey Broudreau, City Clerk

CERTIFICATE OF ADOPTING

I hereby certify that the foregoing is a true copy of the Emergency Ordinance passed at the regular meeting of the City Council held on the 21<sup>st</sup> DAY OF April 2026

\_\_\_\_\_  
Tracey Broudreau, City Clerk

Notice Published:

First Reading:

Second Reading: Immediate

Published:

Effective Date: \_\_\_\_\_



Resolution No. 2026-093  
April 21, 2026

**RESOLVED BY THE COUNCIL OF THE CITY OF YPSILANTI:**

That an emergency ordinance entitled "An ordinance to impose an emergency moratorium on issuance of new zoning permits for data centers in the City of Ypsilanti for 60 days." be approved and given immediate effect.

OFFERED BY: \_\_\_\_\_

SUPPORTED BY: \_\_\_\_\_

YES:            NO:            ABSENT:            VOTE:



**CITY OF YPSILANTI  
TRAFFIC CONTROL ORDER**

**DATE:** 7 April 2026

**ORDER NO:** 2026-02

---

**LOCATION:** 300 Block of Washtenaw Avenue

---

**ORDER:** Remove Parking Meters.

---

**REASON:** The meters on this block are a relic of EMU College of Business, and parking is underutilized. Unrestricted parking can be permitted here. Handicap parking to remain.

---

Approved by: \_\_\_\_\_  
Andrew Hellenga, City Manager

Prepared by: Bonnie Wessler

---

Date Completed: \_\_\_\_\_ By: \_\_\_\_\_

---

cc: City Manager  
Fire Chief  
Police Chief  
DPS Director

cc: City Clerk  
Police Chief  
City Planner  
DDA

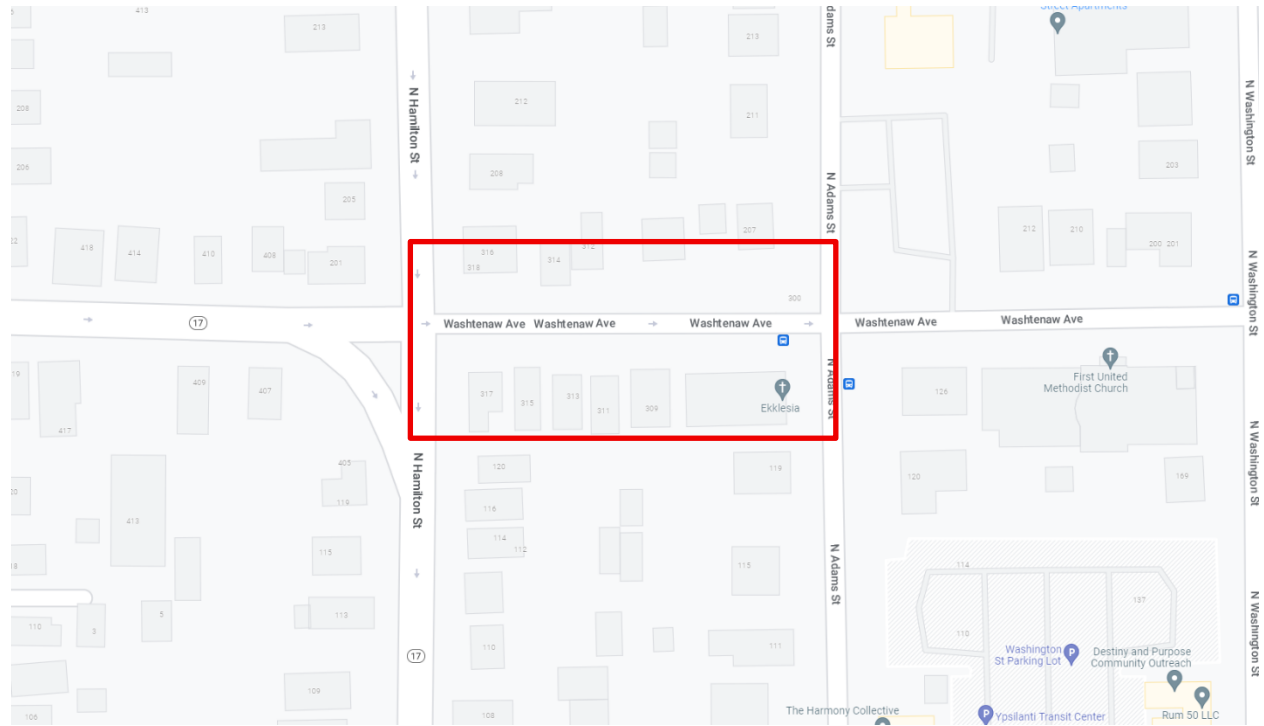



**CITY OF YPSILANTI  
TRAFFIC CONTROL ORDER**

**DATE:** 7 April 2026

**ORDER NO:** 2026-01

---

**LOCATION:** Prospect Street railroad bridge  
Cross Street river bridge  
LeForge Street river bridge

---

**ORDER:** Update weight limit signage for each bridge as follows:  
Prospect: 17 T, 19 T, 25 T  
Cross: 42 T, 45 T, 52 T  
LeForge: 41 T, 41 T, 49 T

---

**REASON:** Recent bridge inspections.

---

Approved by: \_\_\_\_\_  
Andrew Hellenga, City Manager

Prepared by: Bonnie Wessler

---

Date Completed: \_\_\_\_\_ By: \_\_\_\_\_

---

cc: City Manager  
Fire Chief  
Police Chief  
DPS Director

cc: City Clerk  
Police Chief  
City Planner  
DDA



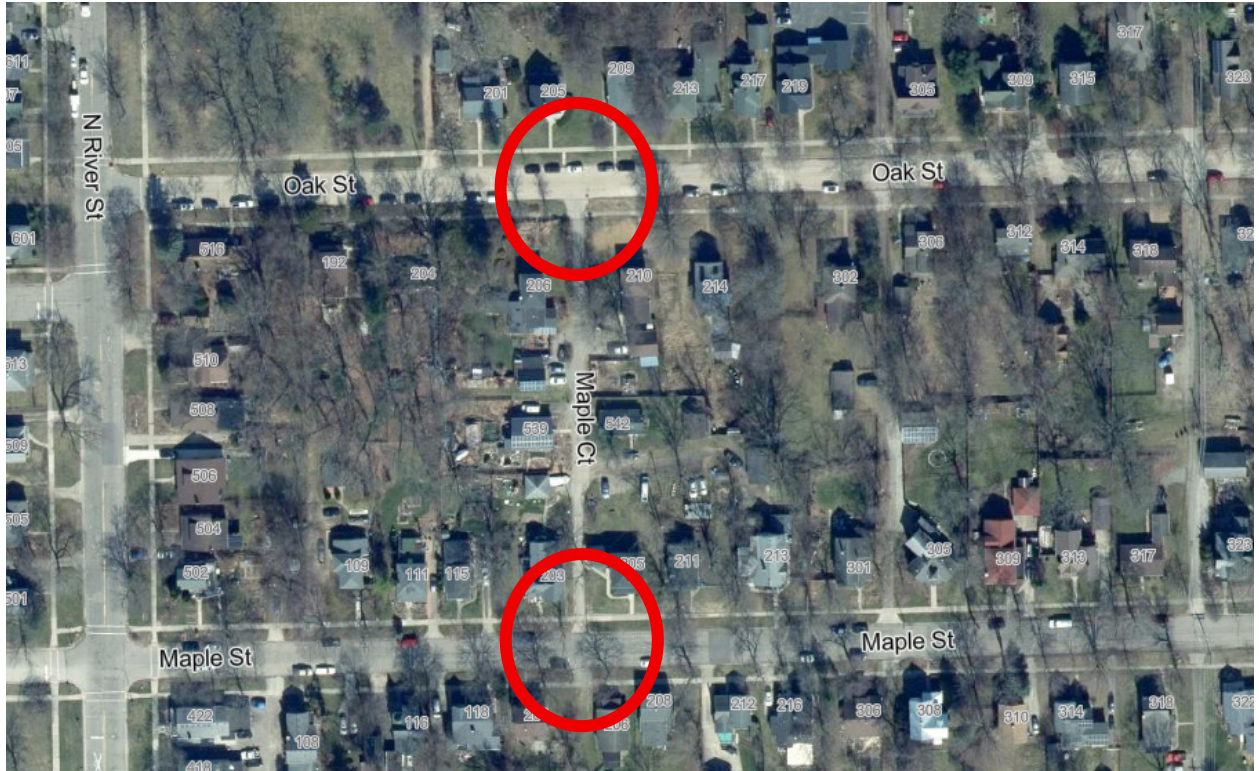



**CITY OF YPSILANTI  
TRAFFIC CONTROL ORDER**

**DATE:** 7 April 2026

**ORDER NO:** 2026-

---

**LOCATION:** 300 Block of Washtenaw Avenue, remove westernmost space

---

**ORDER:** Place "no parking here to corner" signage approximately 30' east of crosswalk at Hamilton.

---

**REASON:** The space closest to the Washtenaw/Hamilton intersection will be occupied by permanent flexible posts to define a "bumpout" to help encourage drivers in the right-hand lane of Washtenaw to turn right, as mandated.

---

Approved by: \_\_\_\_\_  
Andrew Hellenga, City Manager

Prepared by: Bonnie Wessler

---

Date Completed: \_\_\_\_\_ By: \_\_\_\_\_

---

cc: City Manager  
Fire Chief  
Police Chief  
DPS Director

cc: City Clerk  
Police Chief  
City Planner  
DDA

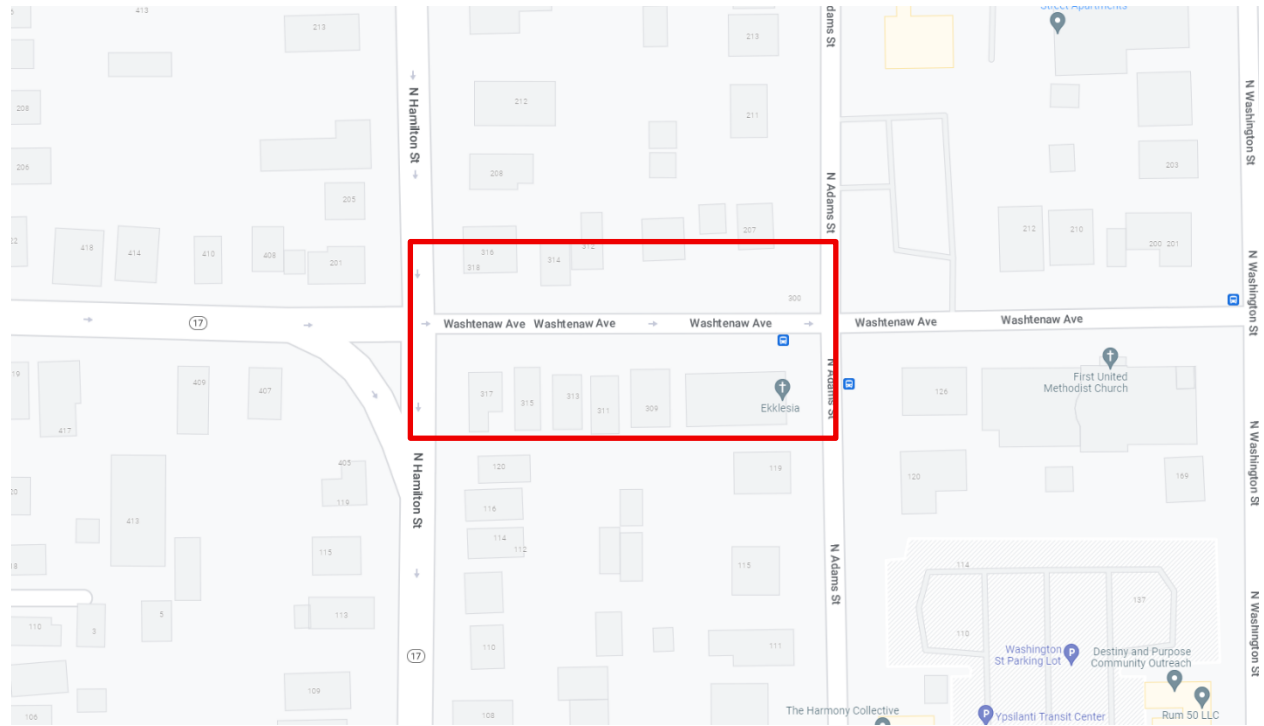



**CITY OF YPSILANTI  
TRAFFIC CONTROL ORDER**

**DATE:** 7 April 2026

**ORDER NO:** 2026-

**LOCATION:** Maple Court, north intersection (Oak) and south intersection (Maple)

**ORDER:** Place "no parking between signs" signage on Oak and Maple immediately opposite intersection with Maple Court, and "no parking here to corner" signs 20' from the intersection, on the same side of the street as Maple Ct.

**REASON:** Maple Court is a small and steep north-south street linking Oak and Maple Streets. When cars are parked in the areas opposite the end of this street, it becomes very challenging to navigate the intersection safely with larger vehicles, such as trash, recycling, and plow trucks; in these cases trucks must mount a curb to make the turn. Parking within an intersection is already prohibited; signage is for clarity, as Maple Court may appear more similar to alleys, and to ensure clear and safe turning movements.

Approved by: \_\_\_\_\_  
Andrew Hellenga, City Manager

Prepared by: Bonnie Wessler

Date Completed: \_\_\_\_\_

By: \_\_\_\_\_

cc: City Manager  
Fire Chief  
Police Chief  
DPS Director

cc: City Clerk  
Police Chief  
City Planner  
DDA

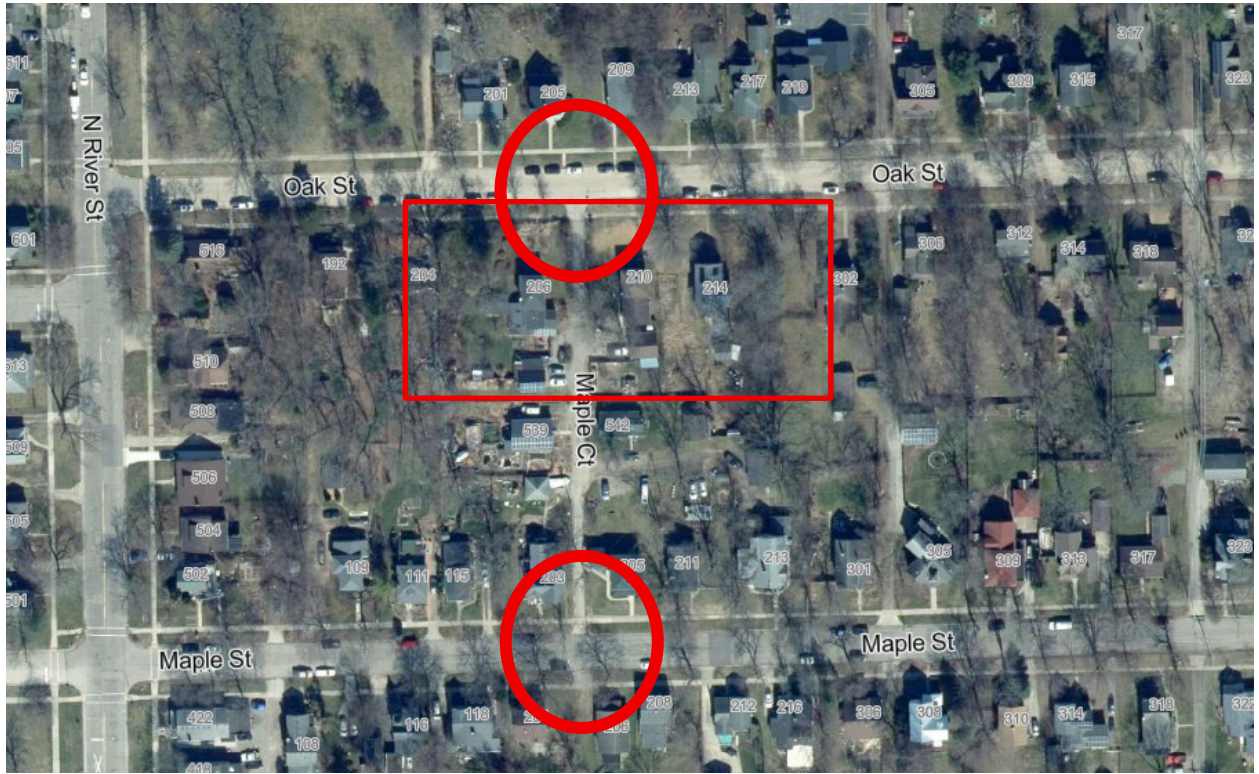



**CITY OF YPSILANTI  
TRAFFIC CONTROL ORDER**

**DATE:** 7 April 2026

**ORDER NO:** 2026-

---

**LOCATION:** 300 block North Normal, Ballard St Parking Lot, North Adams Parking Lot, North Huron Parking Lot, South Huron Parking Lot

---

**ORDER:** Place "Electric vehicle parking only, charging station" signage with "tow away" placard at EV charging stations

---

**REASON:** EV charging stations have been placed in the above-named parking areas. Some are active; some are not yet. As the stations are activated, place the appropriate signage to ensure stations are accessible.

---

Approved by: \_\_\_\_\_  
Andrew Hellenga, City Manager

Prepared by: Bonnie Wessler

---

Date Completed: \_\_\_\_\_ By: \_\_\_\_\_

---

cc: City Manager  
Fire Chief  
Police Chief  
DPS Director

cc: City Clerk  
Police Chief  
City Planner  
DDA



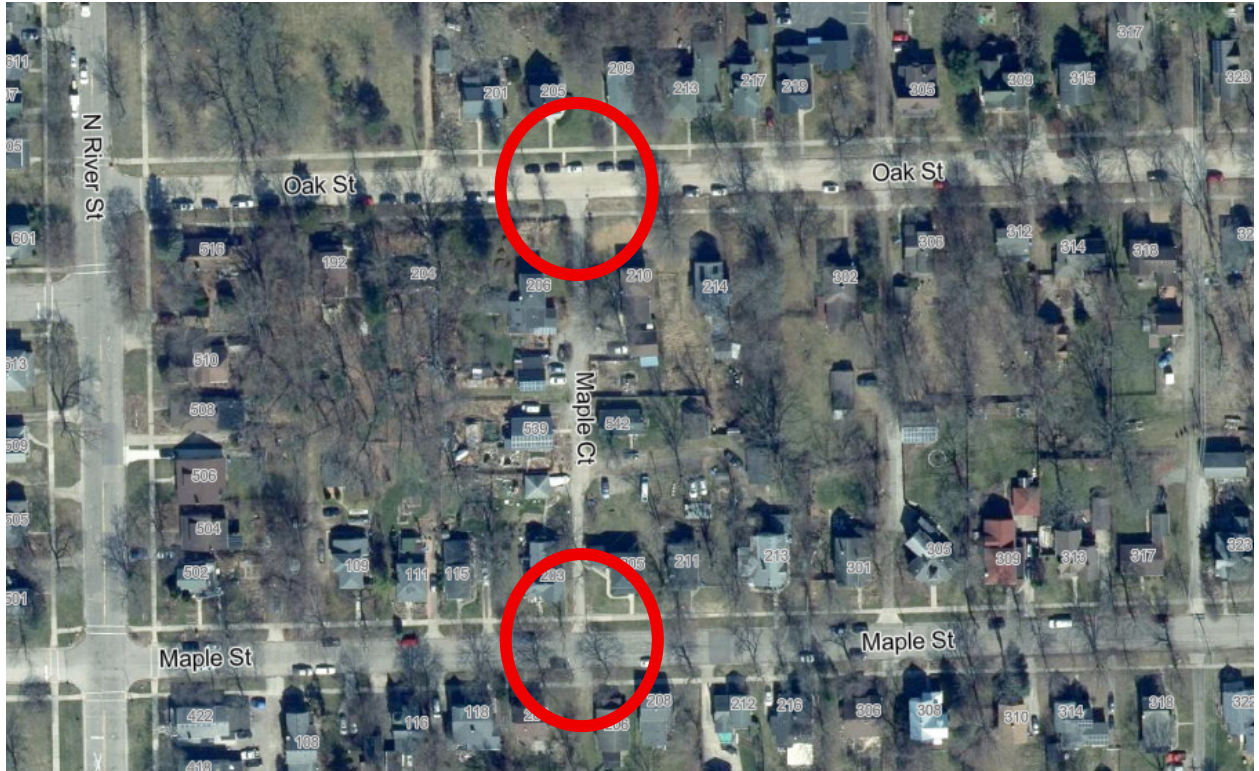



**CITY OF YPSILANTI  
TRAFFIC CONTROL ORDER**

**DATE:** 7 April 2026

**ORDER NO:** 2026-06

---

**LOCATION:** 300 Block of Ferris Street

---

**ORDER:** Remove Parking Meters; replace with 4-hour free parking; install R7-8 handicap permit parking sign for easternmost space.

---

**REASON:** The meters on this block are underutilized. Time-limited parking can be permitted here to serve adjoining post office and other commercial uses. Handicap parking to be added.

---

Approved by: \_\_\_\_\_  
Andrew Hellenga, City Manager

Prepared by: Bonnie Wessler

---

Date Completed: \_\_\_\_\_ By: \_\_\_\_\_

---

cc: City Manager  
Fire Chief  
Police Chief  
DPS Director

cc: City Clerk  
Police Chief  
City Planner  
DDA



# CITY OF YPSILANTI TRAFFIC CONTROL ORDER

**DATE:** 7 April 2026

**ORDER NO:** 2026-07

**LOCATION:** 500 Block of West Cross

**ORDER:** Install "No Parking, Wednesdays 6am to 9am" on south side

**REASON:** This block receives curbside recycling and trash pickup from the City and other vendors. If cars are parked in that area, rubbish pickup is significantly more difficult and dangerous for workers and drivers.

Approved by: \_\_\_\_\_  
Andrew Hellenga, City Manager

Prepared by: Bonnie Wessler

Date Completed: \_\_\_\_\_ By: \_\_\_\_\_

cc: City Manager  
Fire Chief  
Police Chief  
DPS Director

cc: City Clerk  
Police Chief  
City Planner  
DDA



**CITY OF YPSILANTI  
TRAFFIC CONTROL ORDER**

**DATE:** 7 April 2026

**ORDER NO:** 2026-01

---

**LOCATION:** Prospect Street railroad bridge  
Cross Street river bridge  
LeForge Street river bridge

---

**ORDER:** Update weight limit signage for each bridge as follows:  
Prospect: 17 T, 19 T, 25 T  
Cross: 42 T, 45 T, 52 T  
LeForge: 41 T, 41 T, 49 T

---

**REASON:** Recent bridge inspections.

---

Approved by: \_\_\_\_\_  
Andrew Hellenga, City Manager

Prepared by: Bonnie Wessler

---

Date Completed: \_\_\_\_\_ By: \_\_\_\_\_

---

cc: City Manager  
Fire Chief  
Police Chief  
DPS Director

cc: City Clerk  
Police Chief  
City Planner  
DDA



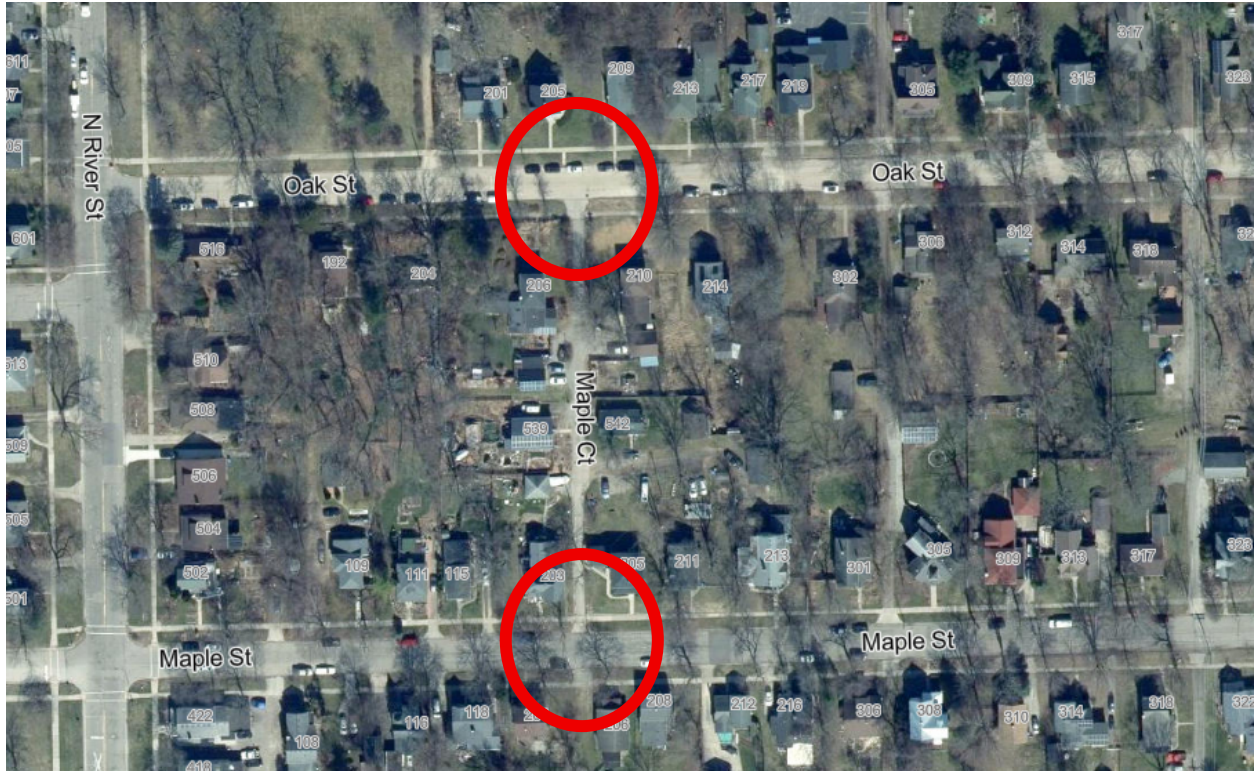



Resolution No. 2026-094  
April 21, 2026

**RESOLVED BY THE COUNCIL OF THE CITY OF YPSILANTI:**

That the public hearing for an ordinance entitled "Traffic Control Orders 2026-001 through 2026-06 ." be officially closed.

OFFERED BY: \_\_\_\_\_

SUPPORTED BY: \_\_\_\_\_

YES:            NO:            ABSENT:            VOTE:



REQUEST FOR LEGISLATION  
April 21, 2026

For: Mayor and City Council

From: Amber Fellows, Council Member, Desirae Simmons, Council Member

Subject: Resolution No. 2026-096, A Resolution to Defund ICE and CBP, Halt Deportation Operations, and Protect Ypsilanti Residents

---

SUMMARY & BACKGROUND:

RECOMMENDED ACTION:

ATTACHMENTS:

1. Resolution No 2026-096 ICE
2. Rutherford Pool MOU Executed\_Redacted

---

CITY MANAGER APPROVAL:

COUNCIL AGENDA DATE: April 21, 2026

CITY MANAGER COMMENTS:

FISCAL SERVICES DIRECTOR APPROVAL:



**RESOLVED BY THE COUNCIL OF THE CITY OF YPSILANTI:**

**A Resolution to Defund ICE and CBP, Halt Deportation Operations, and Protect Ypsilanti Residents**

WHEREAS, ICE and CBP agents have violently arrested civilians—including U.S. citizens—deployed chemical weapons in residential areas, and shot at least nine individuals since September 2025, three fatally: Renee Good, Alex Pretti, and Silverio Villegas González; and

WHEREAS, the One Big Beautiful Bill Act gave ICE and CBP \$170 billion at the expense of housing, healthcare, and education, while detention conditions have led to 37 deaths in ICE custody since January 2025; and

WHEREAS, “border czar” Tom Homan has refused to rule out deploying ICE at polling places, threatening voter intimidation; and

WHEREAS, Ypsilanti protects residents through Ordinance No. 1281 (2017) and Resolution No. 2026-038, barring city resources for civil immigration enforcement and restricting federal entry to city facilities without a judicial warrant; and

WHEREAS, on January 27, 2026, ICE detained Ypsilanti parents at a school bus stop, and on March 10, 2026, abducted small business owner and father Miguel Rosas Ruiz; and

WHEREAS, at least 15 people have been abducted by ICE in and around Ypsilanti since 2025; and

WHEREAS, more than 165 ICE deportation flights departed Willow Run Airport in Ypsilanti in 2025, yet the Wayne County Airport Authority refuses to halt them; and

WHEREAS, the State of Michigan and City of Romulus are suing to block a proposed 500-person ICE detention facility near an elementary school;

NOW, THEREFORE, BE IT RESOLVED BY THE CITY COUNCIL OF YPSILANTI:

A. The Council calls on Congress to immediately cease all funding for ICE and CBP, redirecting those resources to housing, healthcare, and education.

B. The Council directs the City Clerk and City Manager to coordinate with MIRA and local rights orgs within 60 days to:

- Distribute Know Your Rights literature in multiple languages to all Ypsilanti households;
- Partner with AAATA to promote Know Your Rights on public transit and in public spaces;
- Develop an outreach and polling place operations plan to ensure residents can vote without fear of voter intimidation;
- Make city spaces free for related community trainings.

C. The Council supports the lawsuit against the proposed Romulus ICE detention facility and calls on the city attorney to explore amicus options in support of the plaintiffs.

D. The Council urges the Wayne County Airport Authority Board to exercise its authority over airport facilities by reviewing and, where legally permissible, limiting their use for ICE deportation flights.

E. The Council urges Attorney General Dana Nessel to investigate the abduction of Miguel Rosas Ruiz, pursue legal action against unlawful federal enforcement, and calls on Michigan's congressional delegation to advocate for his case.

F. The City Clerk shall send this resolution to: Ypsilanti's state and federal delegation; Attorney General Nessel; Wayne County Airport Authority Board; Michigan Immigrant Rights Center (MIRC); Movement for Immigrant Rights Action (MIRA); ACLU of Michigan; AAATA; Washtenaw County Board of Commissioners; Washtenaw County Sheriff; Romulus Mayor and Council; and Governor Whitmer.

G. The City Manager shall commit necessary budgetary resources to support the Clerk's office in carrying out this resolution, including printing, translation, mailing, polling place operations, and staffing. The Council authorizes up to \$10,000 from the general fund for immediate expenses pending budget adoption.

OFFERED BY: \_\_\_\_\_

SUPPORTED BY: \_\_\_\_\_

YES:            NO:            ABSENT:            VOTE:

# CITY OF YPSILANTI AND FRIENDS OF RUTHERFORD POOL, INC.

## Pool Agreement

This Agreement is entered into on this 18<sup>th</sup> day of September 2012, by the City of Ypsilanti, a Michigan Home Rule City of 1 South Huron Street, Ypsilanti, MI 48197 (City), and Friends of Rutherford Pool (Friends), a Michigan nonprofit, federally tax exempt 501C3 corporation formed for the purposes described in this agreement.

## Background

The City owns Rutherford Pool, (the Pool) a swimming pool located at 975 North Congress, Ypsilanti, MI 48197. The City has operated the Pool for many years. From 2004-2011 the informal Friends of the Rutherford Pool has operated the Pool on behalf of the City.

The parties recognize that the Pool is a valuable community asset for residents and visitors in the City, Ypsilanti Charter Township and surrounding areas.

The City is interested in providing recreation opportunities for residents but does not have current funds available for that purpose.

The Friends are interested in continuing the operation of the Pool, and are ready, willing and able to assist the city in continuing the operation of the Pool.

The Pool is in need of substantial repairs and/or reconstruction.

The City closed the Pool at the end of the 2011 season and does not have current resources to open or operate the Pool during the 2012 season or beyond.

The Friends have asked the City to transfer complete operation and management of the Pool to the Friends on suitable terms and conditions provided that all costs are assumed by the Friends.

The City is willing to transfer complete operation and management of the Pool to the Friends and grant a 20 year lease of the Pool to the Friends.

This agreement details how the parties will work together toward reconstruction of the Pool, operation of the Pool, and to specify the details of any and all future agreements between the parties regarding the Pool.

The City intends the Friends to completely finance the design, construction, reconstruction and operation of the Pool. The City wants the project to succeed and will consider, in its sole discretion, providing a limited financial contribution toward construction costs in order to supplement revenues necessary to reconstruct the Pool, as agreed to by both entities.

In consideration of the above, City and Friends intend to work together in good faith to do the following in order to construct, operate and maintain the Pool.

### **General**

1. Pool. The parties agree that the Pool consists of the existing swimming pool, pool building, related pool equipment and any other element agreed to by the parties. An exact legal description will be prepared when and if needed. In the meantime, the parties agree that the Pool includes a rectangular parcel of land in Recreation Park, city of Ypsilanti, Washtenaw County, Michigan, surrounding the pool, with 147.5 feet of frontage on Congress Street and a depth of 378 feet, the Westerly boundary of which is 15 feet from the pool building, as shown on Exhibit B, attached hereto. Friends intends to donate the cost of improvements to the Pool, which will remain under the ownership of the City, subject to a 20 year lease to the Friends.
2. Michigan Natural Resources Trust Fund (MNRTF) Grant. Ypsilanti City Council passed a resolution submitting a grant application on behalf of the Friends on March 29, 2011 contingent on the Friends meeting certain financial obligations related to operating a pool including securing an MNRTF grant.
3. Endowment/Maintenance Funds. The Friends have raised funds for the design, construction, operation and maintenance of the Pool, and Friends desire to work together regarding the design, operation, and maintenance of the Pool. Ten percent (10%) of all non donor-designated funds raised by the Friends of Rutherford Pool, or a minimum of \$35,000, whichever is greater, shall be allocated to a fund designated the Friends of Rutherford Pool, Inc. through the Ann Arbor Area Community Foundation by the end of the pool warranty period. This endowment fund will be held in reserve for emergency maintenance expenses and will be available for future capital improvements to the pool. This endowment must maintain a balance of \$35,000 at all times.
4. City of Ypsilanti. City, has submitted a grant application to the Michigan Natural Resources Trust Fund to reconstruct Rutherford Pool at Recreation Park and agrees to provide material support in the form of documentation, information, expertise and communications to the extent it is able given limited financial resources; contingent on: (1) City's receipt of funds raised by Friends or others providing 100% of the costs of design, development and construction

of the Pool; (2) City's receipt of proof of funds for maintenance and operation costs, or approval of a funding mechanism for the provision of these funds; and, (3) City's approval of the Pool design. (4) City will serve as financial agent, including payment of invoices with all approved subcontractors, as well as providing reporting to the state for NRTF grant. (5) The City will account for all money being provided to the City by the Friends in support of the reconstruction project. (6) other inkind services including building and DPS support/oversight, (7) City will waive all permit fees, (8) City will contribute up to \$25,000 to complete the reconstruction, if needed.

5. Friends of Rutherford Pool. Friends with volunteer members have raised funds, opened and operated the Pool since 2004. Friends will continue to perform as a nonprofit 501(c) (3) organization.
6. Environmental Responsibility. It is the intention of the parties that the Pool will meet or exceed all requirements for operating a public pool.
7. Rutherford Pool Fund. Friends of Rutherford Pool agrees to fund the design, development, construction, operation and maintenance of the Pool with donations collected for the benefit of the Pool by the Friends of the Rutherford Pool, a temporary fund held by the Ann Arbor Area Community Foundation. City intends to accept all donations as a gift or grant subject to City Council approval of any gift or grant conditions.
8. Term. Friends of the Rutherford Pool, Inc. agrees to operate and maintain the Pool for the life of all grants

## **Design**

1. Pool Design. The parties agree that the Pool shall be designed to be constructed in multiple phases. The elements of each phase shall be designed so that the City can demolish and construct and Friends can operate an entire phase, if funding is available for the next phase of the project.
2. Consultant. Friends agrees to contract with a qualified design consultant, with City approval, to provide all design and engineering documents required for construction of the Pool. The Friends will pay for the costs of design, engineering and inspection costs.
3. Cooperation. Friends and the City intend to work together cooperatively along with the consultant to ensure that the Pool design meets all project goals.
4. Timing. City will commence Pool design after award of the MNRTF grant. Friends will be responsible for all costs for Pool design.

5. Final Design. City and Friends shall agree upon a plan for the design and configuration of the Pool prior to the initiation of any work at the site. Upon completion of the Pool design, City will follow all established state laws, City ordinances and procedures. The final design of the Pool shall be subject to City Council approval.

## **Construction**

1. Construction Contract. City will contract for construction of the Pool subject to all City policies and ordinances regarding procurement, contracting and construction. City will prepare bid/construction documentation and manage the competitive bid process and project development. Friends will review and provide assistance in the selection of responsible bidders.
2. Funding of Pool Construction. Friends will pay all costs for the management and construction of the Pool with donated funds. City will not provide any funding for the construction of the Pool.
3. Timing of Construction. City will commence construction of any phase that has been completely funded within a reasonable amount of time. Once funding for each phase is complete, the City and Friends will develop a schedule for completion of each particular phase.
4. Phased Construction. City only intends to commence construction of the approved Pool design conditioned upon the prior receipt of funds to complete the construction, operation and maintenance of any given phase of the Pool, including:
  - a. All site preparation and construction costs, including a 7% contingency, based on a construction bid, or verified cost received within 30 days of the date of commencement of construction.
5. Construction Agreement. City and Friends agree to the following roles and responsibilities during construction.
  - a. City will consult with Friends on any issues relating to changes in design during construction.
  - b. Parties acknowledge that the Ann Arbor Area Community Foundation may be added as an additional party to specify the timing and distribution of funds.

- c. Approval of Pool design by Friends and City.
- d. Any changes increasing costs to the design and configuration of the Pool shall require the prior written approval of both parties.
- e. Friends will provide cost estimates for the construction of each phase of the project.
- f. Friends shall have funds sufficient pay the cost of next phase on hand before designing and bidding phases of the project.
- g. The Friends will be entitled to any salvage proceeds directly related to this project and ongoing Pool operations.

### **Operations and Maintenance**

1. Budget. Friends will develop a comprehensive operation and maintenance budget for the Pool (Pool) and will present the budget to the City for review and approval as part of the City's standard budget cycle.
2. Maintenance. The Friends will maintain, in good working condition, the Pool and any upgrades or improvements that it initiates, contracts or executes. All maintenance of the Pool shall be completed by the Friends
3. Funding of Operations and Maintenance. Friends will pay all costs for the operations and maintenance of the Pool with donated or other funds.
4. Annual Review of Memorandum of Understanding. City will review The Operation/Maintenance Plan on an annual basis at a meeting between the City and Friends The Operation/Maintenance Plan shall be adjusted as future circumstances may warrant based on operational and maintenance experience at the Pool, and available funding.
5. Pool Rules and Regulations. Friends agree to develop reasonable rules and guidelines for the Pool that address issues such as , user requirements, hours of operation, seasonal schedule, general etiquette, use of the Pool, and other issues that are common to municipal pools.
6. Staffing and monitoring. Friends will select, recommend for hiring and provide for the ongoing training and professional development of all Pool staff in accordance with City, County and State requirements. The City agrees to perform criminal background checks and be the employer of record for persons employed to operate the Pool as recommended for employment by Friends at no

cost to the City. These employees will be paid through revenues generated by Friends. The Friends will also pay to the City any- actual and overhead costs associated with hiring, screening and processing payroll for the employees.

7. Safety and enforcement. Friends will meet or exceed any City, County and State requirements for the safe handling of supplies and chemicals necessary for the operation of the Pool and Pool, as well as keeping appropriate logs of water testing, safety and employee qualifications and training; arrange for all required pool inspections and provide an appropriate representative to address questions.
8. Signage. Friends will prominently post rules at entrances to the Pool.
9. Insurance. Friends shall obtain and maintain the minimum liability insurance as set forth in Attachment A, which may be reviewed and adjusted annually by City.

**Lease.** The City shall lease the Pool to the Friends for a period of 20 years on the terms and conditions of the 20 year lease attached hereto and made a part of this agreement.

**Default.**

If the Friends break the terms of the agreement, or default on the lease, 100% of their assets and investment (**excluding the pool endowment**) become the property of the City.

CITY OF YPSILANTI

FRIENDS OF RUTHERFORD POOL, INC.

By:

[Redacted signature]

Paul Schreiber  
Mayor

Date  
9-18-2012

By:

[Redacted signature]

Frances McMullan  
City Clerk

Date  
9-19-12

APPROVED AS TO FORM

By:

[Redacted signature]

John Barr  
City Attorney

Date

## ATTACHMENT 'A'

### Insurance.

- A. Following incorporation, as required in Paragraph 1 of this Agreement, the Friends shall provide, at its own cost and expense, the following insurance to the City in insurance companies licensed and/or approved in the State of Michigan:
- i. Workers' Compensation insurance with Michigan statutory limits and employers' liability insurance with minimum limits of \$100,000 each accident.
  - ii. General Liability insurance with a minimum of liability per occurrence of \$1,000,000 Combined Single Limit (Bodily Injury/Property Damage). This insurance shall indicate on the Certificate of Insurance the following coverage:
    1. Premises – Operations
    2. Independent Contractor and Sub-Contractors
    3. Products and Completed Operations
    4. Broad Form Contractual
    5. Broad Form Liability Endorsement
  - iii. Automobile Liability insurance with minimum limits of liability, per occurrence, of \$500,000 Combined Single Limit (Bodily Injury/Property Damage) unless otherwise indicated in the "Special Conditions" of the Contract specifications. This insurance shall include for bodily injury and property damage the following coverage:
    1. Owned automobiles
    2. Hired automobiles
    3. Non-owned automobiles
  - iv. Disability Benefits: The Friends shall provide proof of compliance with the Disability Benefits Law. (If applicable).
  - v. Additional insurance may be required on an individual basis for extra hazardous contracts and specific service agreements. If such additional insurance is required for a specific contract, that requirement will be described in the "Special Conditions" of the contract specifications.
- B. Each certificate or policy shall require that, thirty days prior to cancellation or material change in the policies, notice thereof shall be given to the City by registered mail, return receipt requested, for all of the stated insurance policies. All such notices shall name the City and identify the contract number.
- C. All property losses shall be made payable to and adjusted with the City. In order to determine financial strength and reputation of insurance carriers, all companies providing the coverage required shall be licensed or approved by the Insurance Bureau of the State of Michigan and shall have a financial rating not

lower than XI and a policyholder's service rating no lower than B+ as listed in A.M. Best's Key Rating Guide, current edition. Certificates of insurance shall note A.M. Best's Rating. Companies with ratings lower than B+:XI will be acceptable only upon written consent of the City Manager.

D. All policies and certificates of insurance of the Friends shall contain the following clauses

- i. The clause "other insurance provision: in a policy, in which the City is named as an insured, shall not apply to the City.
- ii. The insurance companies issuing the policy or policies shall have no recourse against the City (including its agents and agencies as aforesaid) for payment of any premiums or for assessments under any form of policy.
- iii. Any and all deductibles in the above described insurance policies shall be assumed by and be for the account of, and at the sole risk of, the Friends.
- iv. The City (at its option) shall be listed as an Additional Named Insured on the following insurance coverage provided by the Friends.

YES <input checked="" type="checkbox"/>	NO <input type="checkbox"/>	1. Comprehensive General Liability
YES <input checked="" type="checkbox"/>	NO <input type="checkbox"/>	2. Automobile Liability
YES <input checked="" type="checkbox"/>	NO <input type="checkbox"/>	3. Owners Contractors Protective Liability





REQUEST FOR LEGISLATION  
April 21, 2026

For: Mayor and City Council

From: Amber Fellows, Council Member, Desirae Simmons, Council Member

Subject: Resolution No. 2026 - 097, A Resolution Directing \$1,000,000 for a City-Run Community Responder Program and Requesting County Buy-In

---

SUMMARY & BACKGROUND:

RECOMMENDED ACTION:

ATTACHMENTS:

1. Resolution No 2026-096 1M

---

CITY MANAGER APPROVAL:

COUNCIL AGENDA DATE: April 21, 2026

CITY MANAGER COMMENTS:

FISCAL SERVICES DIRECTOR APPROVAL:



**RESOLVED BY THE COUNCIL OF THE CITY OF YPSILANTI:**

**A Resolution Directing \$1,000,000 for a City-Run Community Responder Program and Requesting County Buy-In**

WHEREAS, on January 21, 2025, the City of Ypsilanti adopted Resolution No. 2025-008, requesting County funding for an unarmed crisis response program and directing an RFP; and

WHEREAS, the need for a community-based crisis response model has grown more urgent, with residents demanding care, prevention, and harm reduction; and

WHEREAS, the City must set aside funds to establish a Community Responder Program for mental health emergencies, substance use, homelessness, and other public health calls; and

WHEREAS, a two-year budget cycle allows for proper fund development and phased implementation;

NOW, THEREFORE, BE IT RESOLVED:

1. Budget Allocation. The City Manager and Finance Director shall allocate \$1,000,000 over the next two budget cycles for fund development and phased implementation of a city-run Community Responder Program.
2. Program Framework. The program shall prioritize trauma-informed, non-coercive interventions; coordinate with EMS and police via a clear triage protocol; and track reduced police involvement and improved care connections.
3. County Buy-In. The Council requests that the Washtenaw County Board of Commissioners commit financial or resource-based buy-in, including direct funding, mental health staff, dispatch integration, or in-kind support, consistent with Resolution No. 2025-008.
4. Collaboration & Reporting. The City Manager shall collaborate with the County, mental health providers, harm reduction specialists, and EMS, and continue working with LEAP to analyze Ypsilanti EMS calls.

BE IT FURTHER RESOLVED, the City Clerk shall send this resolution to the Washtenaw County Board of Commissioners, County Sheriff's Office, County Prosecutor's Office, and County Administrator.

OFFERED BY: \_\_\_\_\_

SUPPORTED BY: \_\_\_\_\_

YES:                      NO:                      ABSENT:                      VOTE:



Resolution No. 2026-098  
April 21, 2026

**RESOLVED BY THE COUNCIL OF THE CITY OF YPSILANTI:**

THAT the minutes of the regular meeting of April 7, 2026 of the Ypsilanti City Council be approved.

OFFERED BY: \_\_\_\_\_

SUPPORTED BY: \_\_\_\_\_

YES:            NO:            ABSENT:            VOTE:



**MINUTES  
REGULAR COUNCIL MEETING  
7:00 PM - Tuesday, April 7, 2026  
Council Chambers  
One South Huron, Ypsilanti, MI 48197**

**I. CALL TO ORDER**

Mayor Brown called the meeting to order at 7:04 p.m.

**II. ROLL CALL**

ROLL CALL

PRESENT at roll call were Mayor Brown, Mayor Pro-Tem Wilcoxon, Council Member McLean, Council member Fellows, Council Member Simmons, Council Member King and Council Member Tooson. ABSENT: None

**III. A MOMENT TO CENTER AND FOCUS**

**IV. AGENDA APPROVAL**

Council Member Tooson moved to Approve the Agenda as Amended. Council Member King seconded the motion. City Manager Hellenga added a walk on item Resolution 2026-091 titled Resolution to Demand the Release of Miguel Rosas Ruiz from the Northlake Detention Facility and Return Him to His Home in Ypsilanti.

Yes: (7) Michelle King, Roland Tooson, Desirae Simmons, Steve Wilcoxon, Nicole Brown, Patrick McLean, Amber Fellows

No: 0 None

Absent: (0)

Council Member Tooson moved to Approve the Consent AGENDA as presented. Council Member Fellows seconded the motion.

Yes: (7) Michelle King, Roland Tooson, Desirae Simmons, Steve Wilcoxon, Nicole Brown, Patrick McLean, Amber Fellows

No: 0 None

Absent: (0)

**V. PUBLIC COMMENT - 60 MINUTES TOTAL (3 MINUTES/EACH SPEAKER)**

22 Members of the public spoke.

**VI. CONSENT AGENDA**

**A. Resolution No. 2026-084 Approving the minutes of the regular meeting of March 17, 2026.**

Council Member Tooson moved to Approve Resolution No. 2026-084 under Consent Agenda Resolution 2026-084A Approving the minutes of the regular meeting of March 17, 2026. Council Member Fellows seconded the motion.

Yes: (7) Michelle King, Roland Tooson, Desirae Simmons, Steve Wilcoxon, Nicole Brown, Patrick McLean, Amber Fellows

No: 0 None

Absent: (0)

**B. Resolution No. 2026-085 Approving its second and final reading of the Arts & Crafts Zoning Text Amendment, Ordinance No. 1458.**

Council Member Tooson moved to Approve Resolution No. 2026-085 under Consent AGENDA Resolution No. 2026-084A. Approving its second and final reading of the Arts & Crafts Zoning Text Amendment, Ordinance No. 1458. Council Member Fellows seconded the motion.

Yes: (7) Michelle King, Roland Tooson, Desirae Simmons, Steve Wilcoxon, Nicole Brown, Patrick McLean, Amber Fellows

No: 0 None

Absent: (0)

**C. Resolution No. 2026-086 Approving the second and final reading of the Electronic Message Board (EMBs) Revisited Zoning Text Amendment, Ordinance No. 1459**

Council Member Tooson moved to Approve Resolution No. 2026-086 under the Consent Agenda Resolution 2026-084A Approving the second and final reading of the Electronic Message Board (EMBs) Revisited Zoning Text Amendment, Ordinance No. 1459. Council Member Fellows seconded the motion.

Yes: (7) Michelle King, Roland Tooson, Desirae Simmons, Steve Wilcoxon, Nicole Brown, Patrick McLean, Amber Fellows

No: 0 None

Absent: (0)

**VII. RESOLUTIONS/MOTIONS/DISCUSSIONS**

**A. Resolution No. 2026-091 Resolution to Demand the Release of Miguel Rosas Ruiz from Northlake Detention Facility and Return Him to His Home in Ypsilanti.**

Council Member Simmons moved to Approve the Resolution No. 2026-091 Resolution to Demand the Release of Miguel Rosas Ruiz from Northlake Detention Facility and Return Him to His Home in Ypsilanti. Council Member Fellows seconded the motion.

Yes: (7) Michelle King, Roland Tooson, Desirae Simmons, Steve Wilcoxon, Nicole Brown, Patrick McLean, Amber Fellows

No: 0 None

Absent: (0)

**B. Resolution No. 2026-087 Approving the second and final reading of the Levels of Review Zoning Text Amendment, Ordinance No. 1460.**

Council Member McLean moved to Approve the Resolution No. 2026-087 Approving the second and final reading of the Levels of Review Zoning Text Amendment, Ordinance No. 1460. Mayor Pro-Tem Wilcoxon seconded the motion.

Yes: (7) Michelle King, Roland Tooson, Desirae Simmons, Steve Wilcoxon, Nicole Brown, Patrick McLean, Amber Fellows

No: 0 None

Absent: (0)

**C. TABLED Resolution No. 2026-077 Directing the City Clerk to forward Certificate of Sufficiency for Charter Amendment Petition for Police Funding to County Clerk and Governor.**

Council Member Fellows moved to Approve the Amended Resolution No. 2026-077 Directing the City Clerk to forward Certificate of Sufficiency for Charter Amendment Petition for Police Funding to County Clerk and Governor as presented. Council Member Simmons and Mayor Pro-Tem Wikcoxon seconded the motion.

Yes: (6) Michelle King, Roland Tooson, Desirae Simmons, Steve Wilcoxon, Nicole Brown, Amber Fellows

No: 1 Patrick McLean

Absent: (0)

Council Member Tooson moved to Amend the TABLED Resolution No. 2026-077 Directing the City Clerk to forward Certificate of Sufficiency for Charter Amendment Petition for Police Funding to County Clerk and Governor to read as follows: That City Council has received the Certificate of Sufficiency for a petition for Charter Amendment Titled "There is hereby established a limit on the amount of police expenditures that may be adopted by the city council for any fiscal year. Effective with fiscal year 2025-2026. And for each fiscal year thereafter. The city council shall not adopt a budget with total police expenditures exceeding the police expenditures of the previous fiscal year without approval of the majority of qualified electors voting on a charter amendment pertaining to no other matter, subject to limitation and prohibitions provided by the federal or state constitution. Or by law. As necessary, the city council shall enact ordinances fully and faithfully effectuating this limitation. Police Funding and directs the City Clerk to forward it to the Washtenaw County Clerk for action pursuant to MCL 117.25(3) and the Governor for review pursuant to MCL 117.22.

Council Member Simmons seconded the motion.

Yes: (6) Michelle King, Roland Tooson, Desirae Simmons, Steve Wilcoxon, Nicole Brown, Amber Fellows

No: 1 Patrick McLean

Absent: (0)

Council Member Fellows moved to Amend the TABLED Resolution No. 2026-077 Directing the City Clerk to forward Certificate of Sufficiency for Charter Amendment Petition for Police Funding to County Clerk and Governor. with the PURPOSE to read as follows- **Purpose:** To amend Section 5.04 of the City Charter to limit budgeted expenditures regarding the police department to that established in the prior fiscal year absent approval of a majority of the electorate at a regular city-wide election called for that specific purpose..Council Member King seconded the motion.

Yes: (3) Michelle King, Desirae Simmons, Amber Fellows

No: 4 Roland Tooson, Steve Wilcoxon, Nicole Brown, Patrick McLean

Absent: (0)

**D. Resolution No. 2026-088 Establishing a Historic District Study Committee in order to fully review and explore the recommendations resulting from the 2025 resurvey of Ypsilanti's Local Historic District, and complete the process required for amending the City's Historical Preservation Ordinance.**

Mayor Pro-Tem Wilcoxon moved to Approve Resolution No. 2026-088 Establishing a Historic District Study Committee in order to fully review and explore the recommendations resulting from the 2025 resurvey of Ypsilanti's Local Historic District, and complete the process required for amending the City's Historical Preservation Ordinance. Council Member McLean seconded the motion.

Yes: (7) Michelle King, Roland Tooson, Desirae Simmons, Steve Wilcoxon, Nicole Brown, Patrick McLean, Amber Fellows

No: 0 None

Absent: (0)

**E. Resolution No. 2026-089 Approving a budget amendment to transfer 25% of the 24-25 surplus, in the amount of \$239,397, from the General Fund to the Budget Stabilization Fund; and authorizing the Fiscal Services Department to make the necessary accounting entries and implement this budget amendment.**

Council Member McLean moved to Approve Resolution No. 2026-089 Approving a budget amendment to transfer 25% of the 24-25 surplus, in the amount of \$239,397, from the General Fund to the Budget Stabilization Fund; and authorizing the Fiscal Services Department to make the necessary accounting entries and implement this budget amendment. Mayor Pro-Tem Wilcoxon seconded the motion.

Yes: (7) Michelle King, Roland Tooson, Desirae Simmons, Steve Wilcoxon, Nicole Brown, Patrick McLean, Amber Fellows

No: 0 None

Absent: (0)

9:33p.m. Mayor Brown left the chambers

9:35 p.m. Mayor Brown returned to the chambers.

9:39 p.m. Council Member King moved to extend the meeting until 10:30 p.m. Council Member Simmons seconded the motion.

Motion passed by VOICE

9:55p.m. Council Member McLean left the chambers

9:57 p.m. Council Member McLean returned to the chambers

**F. TABLED Resolution No. 2026-074 Approving the quotes from Detection Systems and Engineering for Facility Security Upgrades at City Hall and the Freighthouse in the total amount of \$41,566.**

Council Member Simmons moved to Approve TABLED Resolution No. 2026-074 Approving the quotes from Detection Systems and Engineering for Facility Security Upgrades at City Hall and the Freighthouse in the total amount of \$41,566 with the approved amendments. Council Member King seconded the motion.

Yes: (6) Council Member King, Council Member Tooson, Council member Simmons, Mayor Pro-Tem Wilcoxon, Mayor Brown, Council Member McLean

No: (1) Council Member Fellows

Absent: (0)

Council Member King moved to Amend TABLED Resolution No. 2026-074 by removing the interior cameras from the Freighthouse and including the requirement of local storage only for the data. Mayor Pro-Tem Wilcoxon seconded the motion.

Yes: (5) Michelle King, Roland Tooson, Steve Wilcoxon, Nicole Brown, Patrick McLean

No: 2 Desirae Simmons, Amber Fellows

Absent: (0)

**G. Resolution No. 2026-090 Approving the request to waive the application, event, and street closure fees totaling \$1,128.40 for the Stop the Gun Violence Community Outreach Event.**

Council Member King moved to Approve Resolution No. 2026-090 Approving the request to waive the application, event, and street closure fees totaling \$1,128.40 for the Stop the Gun Violence Community Outreach Event. Mayor Pro-Tem Wilcoxon seconded the motion.

Yes: (7) Michelle King, Roland Tooson, Desirae Simmons, Steve Wilcoxon, Nicole Brown, Patrick McLean, Amber Fellows

No: 0 None

Absent: (0)

**H. Discussion Regarding Short Term Rental Committee, limited to 10 minutes.**

**VIII. BOARD AND COMMISSION - LIAISON REPORTS**

**A. Police Advisory Commission**

Council Member Tooson stated that YPAC requested to review some policies within the department, and he would follow up at the next meeting. He also noted that the committee is still looking for someone to join the committee and represent Ward 3. Lt. Wist reported (3) new Police Officers are currently in training. The next meeting will be Thursday 4/23 at 6:00 p.m.

**B. Human Relations Commission**

Council Member King spoke about testing a change in meeting days as there have been problems with the current schedule and meeting quorum. Members are interested in putting together a Town Hall meeting and will discuss the possibility at a future meeting. The next meeting will be Monday 4/27 at 6:00p.m.

**C. Parks and Arts Commission**

Council Member McLean had no updates. The next meeting will be Monday 4/20.

**D. Sustainability Commission**

Council Member Simmons stated they will discuss Earth Day at the next meeting on Monday 4/13.

**E. Historic District Commission**

Council Member McLean had no updates.

**F. Planning Commission**

Mayor Pro-Tem Wilcoxon stated they met on 3/18 and spoke of the Zoning Text Amendment on Hard Reduction.

**G. Zoning Board of Appeals**

**IX. LIAISON REPORTS**

**A. SEMCOG Update**

No update given.

**B. Washtenaw Area Transportation Study**

No update given.

**C. Urban County**

No update given.

**D. Ypsilanti Downtown Development Authority**

Mayor Brown reminded everyone that the month of April is Sammy Slam throughout the city and DDA.

**E. Friends of Rutherford Pool**

No update given.

**X. COUNCIL PROPOSED BUSINESS**

**Council Member Simmons** - Further the discussion of AI policies, Asking for proclamations for student volunteers working with Womens Literacy Club., Low Mow May and leaf blower restrictions, Ongoing garbage issues.

**Council Member Fellows** - Requesting an update on the Ruben Peeler and John Andrew Genuine from the YPD perspective.

**Council Member McLean** - Shared positive feedback from a constituent who received emergency assistance from a YPD officer during the No Kings Day event.

**Mayor Pro-Tem Wilcoxen** -- Requested a report from Chief Anderson regarding the Ruben Peeler and John Andrew Genuine incident. Discussion of signage and / or possible barriers at Washtenaw & Hamilton.

**Council Member King** - Senior Center requesting benches to be painted, Questions regarding the revenue from Patient Station fines

**Council Member Tooson** - Discuss community events for the Summer

**XI. COMMUNICATIONS FROM THE MAYOR**

- Shared a wonderful experience celebrating the 205th Celebration of Greek Independence
- Happy to participate in the Perry School Easter Egg Hunt with the community.
- Shared condolences to the family of Coral Springs Florida Vice Mayor Nancy Metayer -Bowen.

**XII. COMMUNICATIONS FROM THE CITY MANAGER**

- Re-engage grants for Grace Solar Programs
- Budget sessions will take place during the month of May.
- Moodys Report City is maintaining its A-1 credit rating.
- Community Services RFP Master Plan update will be coming
- Community Services will be preparing RFP for park bathrooms.
- Carlisle Wortman & Associates Contract

**XIII. COMMUNICATIONS**

**XIV. PUBLIC COMMENT - CONTINUED (3 MINUTES/EACH SPEAKER)**

**XV. ADJOURNMENT**

Mayor Brown adjourned the meeting at 10:27 p.m.

- A. Please click [here](#) to access the City Council Contact Form. This form can be used to submit any comments/concerns you might have about this agenda.**



REQUEST FOR LEGISLATION  
April 21, 2026

For: Mayor and City Council

From: Andrew Hellenga, City Manager

Subject: Resolution No. 2026-099 Authorizing the Mayor and City Clerk to sign the extension agreement for the Washtenaw County Dispatch Contract, subject to the approval of the City Attorney.

---

**SUMMARY & BACKGROUND:**

This contract, originally approved in 2021, is the fifth year of the contract cycle, with a 9% beginning at the start of the Fiscal Year.

In FY 2024-2025, the contract costs were \$106,137.00, per the 9% increase, the city will pay the county \$115,137.00.

**RECOMMENDED ACTION:** Approval

**ATTACHMENTS:**

1. Res approve contract extention to 6-30-27
2. Dispatch Partner Extension Letter Ypsilanti 2026

---

**CITY MANAGER APPROVAL:**

**COUNCIL AGENDA DATE:** April 21, 2026

**CITY MANAGER COMMENTS:**

**FISCAL SERVICES DIRECTOR APPROVAL:**



Resolution No. 2026-099  
April 21, 2026

RESOLUTION TO EXTEND THE WASHTENAW COUNTY DISPATCH CONTRACT TO JUNE 30, 2026

IT IS RESOLVED BY THE COUNCIL OF THE CITY OF YPSILANTI that the Dispatch Contract with Washtenaw County be extended to June 30, 2027, on the same terms and conditions, be it further

RESOLVED, that the Mayor and City Clerk are authorized to sign the extension agreement, subject to the approval of the City Attorney.

OFFERED BY: \_\_\_\_\_

SUPPORTED BY: \_\_\_\_\_

YES:            NO:            ABSENT:            VOTE:



# WASHTENAW COUNTY OFFICE OF THE SHERIFF



EST. 1823

**ALYSHIA M. DYER, SHERIFF**

---

March 23, 2026

To: Washtenaw County Dispatch Contract Service Partners

From: Alyshia M. Dyer, Sheriff

Dear Dispatch Partners:

As previously communicated to our dispatch partners, 2026 is the fifth year of the planned, annual, 9% rate increase. This letter is to formally confirm the updated rates and to share the contract amendment for your review and signature.

As we move to revisit contracts after this year's rate increase, we will continue collaborative discussions and consider recommendations included in the September 2024 final report on the *WCSC Emergency Communications Current Conditions Feasibility Study and Recommendations Report*. We will work together to develop a forward-facing framework that meets the needs of our partners and aligns with the growing capacity of our agency.

The goal of my Office continues to be providing cost-effective and efficient service to the people we collectively serve. Thank you for your ongoing partnership.

As always, please feel free to contact me with any questions.

In Solidarity,

Alyshia M. Dyer, Sheriff

Cc: Matthew Harshberger, Undersheriff  
Leigh Hathaway, Dispatch Operations Manager  
Crystal S. Campbell, Director of Operations

---

*"TOGETHER, WE ARE COMMITTED TO CREATING A SAFER, MORE JUST AND COMPASSIONATE WASHTENAW COUNTY FOR ALL."*

2201 HOGBACK ROAD ◆ ANN ARBOR, MICHIGAN 48105-9732 ◆ OFFICE (734) 971-8400 ◆ FAX (734) 973-4624 ◆ EMAIL SHERIFFINFO@WASHTENAW.ORG



# WASHTENAW COUNTY OFFICE OF THE SHERIFF



EST. 1823

**ALYSHIA M. DYER, SHERIFF**

March 23, 2026

CV 32630.8

Nicole Brown, Mayor  
City of Ypsilanti  
1 South Huron Street  
Ypsilanti, MI 48197

Dear Ms. Brown,

Washtenaw County wishes to amend the contract with your agency. Corporation Counsel has indicated that this amendment could be accomplished by a letter signed by both of us. If this amendment is agreeable to you, please sign and return all copies of this letter. You will receive an executed copy of this letter upon completion.

Accordingly, I hereby amend the Service Contract between Washtenaw County and City of Ypsilanti dated December 21, 2009, as follows:

Amend ARTICLE II – COMPENSATION to extend the contract as follows:

Beginning July 1, 2026, upon the above services and submission of invoices, the City of Ypsilanti will pay the County an amount not to exceed one hundred fifteen thousand, six hundred eighty-nine dollars (\$115,137.00) per year. Price will be set until June 30, 2027.

Amend ARTICLE III – TERM to extend the contract as follows:

“This contract shall be in full force and effect for the term of one year commencing July 1, 2026, terminating on June 30, 2027.”

All other terms and conditions remain the same as in the original contract, subsequent amendments, and any applicable RFP/RFQ.

ATTEST:

WASHTENAW COUNTY

\_\_\_\_\_  
Lawrence Kestenbaum (DATE)  
County Clerk/Register

\_\_\_\_\_  
Gregory Dill (DATE)  
County Administrator



# WASHTENAW COUNTY OFFICE OF THE SHERIFF



*EST. 1823*

**ALYSHIA M. DYER, SHERIFF**

APPROVED FOR CONTENT:

CONTRACTOR

\_\_\_\_\_  
Alyshia M. Dyer (DATE)  
Washtenaw County Sheriff

\_\_\_\_\_  
Accepted by  
Nicole Brown (DATE)  
Mayor

Original: Clerk  
Contractor  
cc: Department  
Purchasing



REQUEST FOR LEGISLATION  
April 21, 2026

For: Mayor and City Council

From: Andrew Hellenga, City Manager

Subject: Resolution No. 2026-100 Approving the change order for the Municipal Lots Rehabilitation to Somerset Paving for the total cost of \$214,200, with the DDA reimbursing the City for up to \$204,200, and authorizing the City Manager to sign the change order on the city's behalf.

---

**SUMMARY & BACKGROUND:**

The Downtown Development Authority will be funding the rehabilitation of both the Freighthouse and the Ballard Street Lots. This was initially brought before Council in September of 2025.

Since the DDA has determined to change scope of the project. Rather than a mill and overlay for the Ballard St. Lot it will be reconstructed. The original price was \$191,950 for both lots. This will increase the cost by \$22,250.00 increasing the total to \$214,200.

Approval of this resolution will authorize the change order.

**RECOMMENDED ACTION:** Approval

**ATTACHMENTS:**

1. Resolution No Ballard
2. \_1LOG OF PROJECT
3. 04-01-26\_Ypsilanti Municipal Lots Rehabilitation\_v2
4. 0094250070 City of Ypsilanti Municipal Lot Rehab\_CO1
5. Bid Tab - 0094250070 City of Ypsilanti Municipal Lot Rehab
6. C-941 Change Order\_Ballard & Freighthouse

---

**CITY MANAGER APPROVAL:**

**COUNCIL AGENDA DATE:** April 21, 2026

**CITY MANAGER COMMENTS:**

**FISCAL SERVICES DIRECTOR APPROVAL:**



**RESOLVED BY THE COUNCIL OF THE CITY OF YPSILANTI:**

**WHEREAS**, The YDDA passed a resolution recommending that the City of Ypsilanti award a contract for the City of Ypsilanti Municipal Lots Rehabilitation to Somerset Paving for the total cost of \$191,950; and

**WHEREAS**, the YDDA has changed the scope of the Ballard St Lot to a full reconstruction increasing the total cost be \$22,250; and

**NOW, THEREFORE, BE IT RESOLVED**, that the Ypsilanti City Council approves the change order for the Municipal Lots Rehabilitation to Somerset Paving for the total cost of \$214,200, with the DDA reimbursing the City for up to \$204,200, and authorizes the City Manager to sign the change order on the city's behalf.

OFFERED BY: \_\_\_\_\_

SUPPORTED BY: \_\_\_\_\_

YES:                      NO:                      ABSENT:                      VOTE:

CITY OF YPSILANTI

LOG OF PROJECT  
MUNICIPAL PARKING LOTS REHABILITATION

OHM:RCMJ

1 of 3

4/01/2026

**DESCRIPTION OF WORK**

The project consists of pavement rehabilitation and reconstruction.

**PROJECT LOCATIONS**

		TYPE OF WORK	PAVEMENT REMOVAL (INCHES)	PAVEMENT REPLACEMENT (INCHES)	AREA (SYD)
#	NAME				
1	Ballard St Lot	Reconstruction	4.0"	4.0"	1,400
2	Freighthouse Lot	Mill and Fill	2.0"	2.0"	2,900

**DEFINITIONS**

“Reconstruction” involves full depth pavement removal, replacement, and pavement striping.

“Mill & Fill” involves full width deep cold milling, full depth pavement patch repairs, and pavement striping.

Traffic shall be maintained throughout the project as provided in the details and Special Provision for Maintaining Traffic.

A “Minor Road” is defined as a side street which terminates or originates at a collector road. This designation affects the limits of work in terms the rehabilitation of the side street approaches and POB and POE approaches. The thickness of the existing pavement is not a determining factor as to whether the street is called a major or minor road. Refer to Special Detail “Work Limits for Residential Streets & Driveway Approaches”.

**GENERAL PLAN NOTES**

The improvements in this proposal shall be done in accordance with City of Ypsilanti Engineering Standards, the Michigan Department of Transportation 2020 Specifications, Supplemental Specifications, and Special Provisions packaged herein.

Asphalt overlay shall be placed within 2 days (48-hours) of milling operations.

**UNDERGROUND UTILITIES**

For the protection of underground utilities and in conformance with Public Act 53, 1974, the contractor shall call Miss Dig (1-800-482-7171) a minimum of three full working days, excluding Saturdays,

Sundays, and Holidays prior to beginning each excavation in areas where public utilities have not been previously located. Miss Dig members will thus be routinely notified. This does not relieve the contractor of the responsibility of notifying utility owners who may not be a part of the "MISS DIG" alert system.

### **EXISTING UNDERGROUND UTILITIES**

The contractor will be responsible for any damage to existing water mains and/or existing sanitary sewer due to the contractor's negligence during the construction of this project.

### **UNSEEN UNDERGROUND STRUCTURES**

During the milling of pavement and pavement repair removal operations, existing drainage, sanitary structures or water main structures may be encountered that have been left below the existing pavement on previous overlay projects. These structure covers shall be adjusted to the proposed finished grade using the pay items provided in the miscellaneous estimates as directed by the Engineer. If an unseen (i.e. buried below the existing pavement due to previous overlay projects) structure casting is damaged in the milling or pavement removal process, the casting will be replaced and paid for separately, as directed by the Engineer. Adjustments will only be paid for once, regardless of the number of adjustments required.

### **ADJUSTING STRUCTURES**

Adjusting structure covers (drainage, sanitary and water main) shall be done in accordance with Section 403 of the 2020 Michigan Department of Transportation Standard Specifications for Construction. Final adjustment of structures shall be made after the placement of the HMA. All structures covers shall be reused unless the existing cover is unsalvageable, as directed by the Engineer. Adjusting sanitary structures and adjusting gate well structures shall also be done in accordance to the included Special Provisions.

### **STATIONING**

None.

### **PAVEMENT MARKINGS**

All markings, shapes and dimensions shall conform to MDOT pavement markings typicals PAVE-900 to PAVE-990 series unless specified otherwise by special provision.

### **ADJUSTING MONUMENT BOXES**

It is the intent that all government corners on this project be preserved and that, where necessary, monument boxes be adjusted, whether shown or not.

### **NOTES APPLYING TO STANDARD PLANS**

Where the following items are called for on the plan sheets, they are to be constructed according to the Michigan Department of Transportation Standard Plan given below opposite each item unless otherwise indicated.

<u>STD PLAN #</u>	<u>TITLE</u>
<u>R-1-G*</u>	Drainage Structures
<u>R-2-D</u>	Manhole Base Type 1
<u>R-7-F</u>	Cover B
<u>R-15-F</u>	Cover K
<u>R-18-F</u>	Cover Q
<u>R-28-J*</u>	Sidewalk Ramp and Detectable Warning Details
<u>R-29-I</u>	Driveway Openings & Approaches, and Concrete Sidewalk
<u>R-30-G</u>	Concrete Curb and Concrete Curb & Gutter
<u>R-44-F</u>	Concrete Pavement Repair
<u>R-80-F</u>	Granular Blanket, Underdrains, Outlet Endings for Underdrains, and Sewer Bulkheads
<u>R-83-C</u>	Utility Trenches
<u>R-96-E</u>	Soil Erosion and Sedimentation Control Measures
<u>R-100-H</u>	Seeding and Tree Planting
<u>WZD-125-E</u>	Temporary Traffic Control Devices

\* - Indicates MDOT Special Detail

# CITY OF YPSILANTI WASHTENAW COUNTY, MICHIGAN

# CITY OF YPSILANTI CITY COUNCIL

INDEX OF SHEETS	
SHEET NO.	DESCRIPTION
1	OVERALL COVER SHEET
2-6	DIVISION A: BALLARD LOT REHABILITATION
7-13	DIVISION B: FREIGHTHOUSE LOT REHABILITATION

## OVERALL COVER SHEET DIVISION A: BALLARD LOT REHABILITATION DIVISION B: FREIGHTHOUSE LOT REHABILITATION

**NICOLE BROWN**  
• MAYOR •

**STEVEN WILCOXEN**  
• MAYOR PRO-TEM •

**Me'CHELLE KING**  
**PATRICK McLEAN**

**DESIRAÉ SIMMONS**  
**AMBER FELLOWS**  
**ROLAND TOOSON**  
• COUNCIL MEMBERS •

**ANDREW HELLENGA**  
• CITY MANAGER •

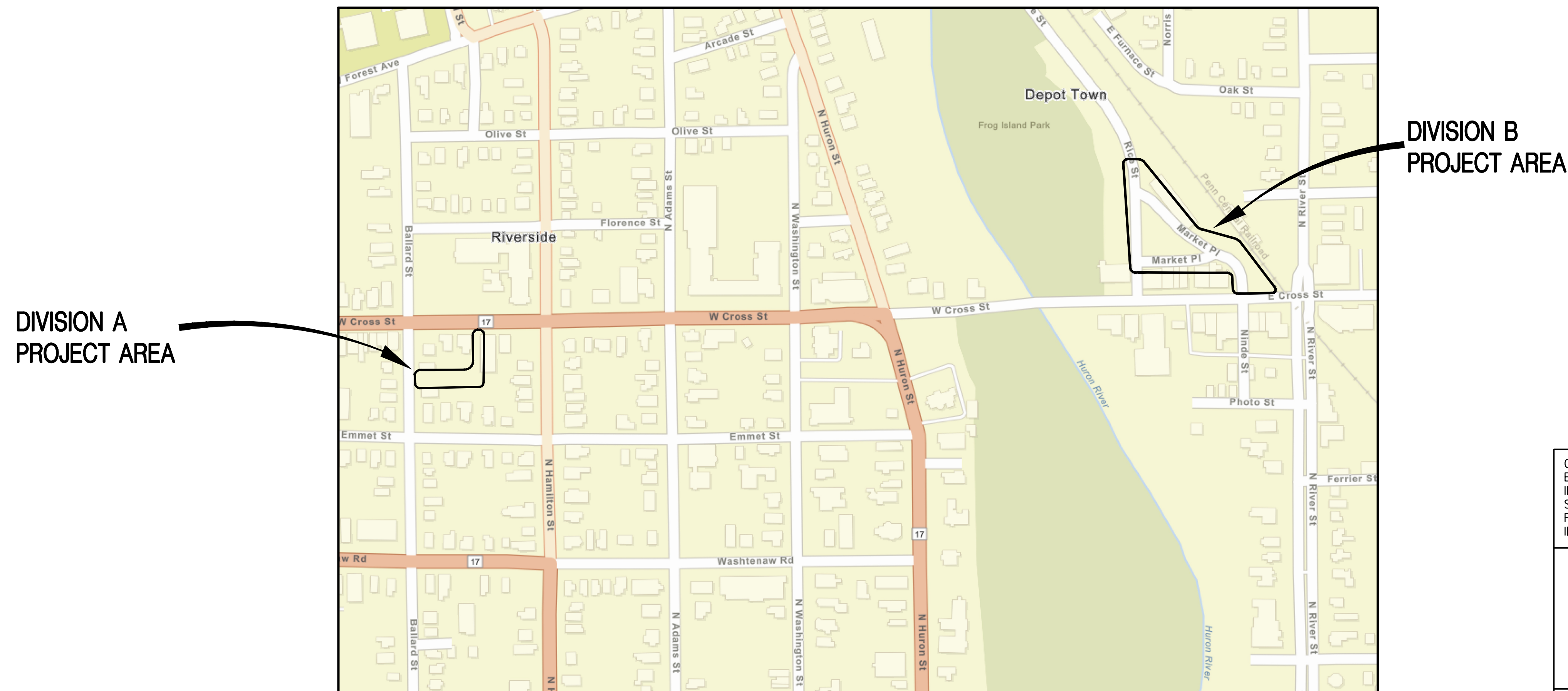

**DIVISION A  
PROJECT AREA**

**DIVISION B  
PROJECT AREA**

**GENERAL PROVISIONS**

THE IMPROVEMENTS COVERED BY THESE PLANS SHALL BE DONE IN ACCORDANCE WITH THE PROPOSAL AND ACCOMPANYING SPECIFICATIONS FOR THIS PROJECT INCLUDING THE 2020 MICHIGAN DEPARTMENT OF TRANSPORTATION STANDARD SPECIFICATIONS FOR CONSTRUCTION, 2025 MICHIGAN MANUAL OF UNIFORM TRAFFIC CONTROL DEVICES, AND THE MICHIGAN DEPARTMENT OF TRANSPORTATION LOCAL AGENCY PROGRAMS GUIDELINES FOR GEOMETRICS DATED 7-24-2017.

THE LOCATION OF ALL PUBLIC UTILITIES SHOWN ON THESE PLANS IS TAKEN FROM THE BEST AVAILABLE DATA. THE CITY OF YPSILANTI WILL NOT BE RESPONSIBLE FOR ANY OMISSION OR VARIATION FROM THE LOCATIONS SHOWN. PURSUANT TO ACTS 173 & 174 OF THE P.A. OF 2013, AS A CONDITION OF THIS CONTRACT, NOTICE SHALL BE GIVEN TO MISS DIG PRIOR TO UNDERGROUND WORK TO BE PERFORMED IN ACCORDANCE WITH THIS CONTRACT, PHONE (800) 482-7171 (OR 811). UTILITY SERVICE CONNECTIONS ARE NOT SHOWN ON THE PLANS AND ARE NOT THE RESPONSIBILITY OF THE CITY OF YPSILANTI.

THE ELEVATIONS SHOWN ON THESE PLANS ARE BASED ON NAVD 1988 VERTICAL DATUM.



CONTRACT FOR:  
BALLARD LOT - THE REHABILITATION OF THE BALLARD STREET MUNICIPAL LOT, INCLUDING THE ALLEY FROM THE SOUTH-SIDE OF THE PARCEL TO WEST CROSS STREET.  
FREIGHTHOUSE LOT - THE REHABILITATION OF THE FREIGHTHOUSE MUNICIPAL LOT, INCLUDING CONCRETE REPAIRS, ADA RAMP INSTALLATION, AND PAVEMENT MARKINGS.



34000 PLYMOUTH ROAD  
LIVONIA, MI 48150  
T: 734.522.6711

PREPARED UNDER THE SUPERVISION OF:



RACHEL JACKSON

**6201067358**  
Registration No.

**04/01/2026**  
Date

**REVISIONS**

08/28/2025 BID SUBMITTAL	
09/04/2025 ADDENDUM NO 1	
04/01/2026 CHANGE ORDER NO 1	
PROJECT NO. 0094-25-0070	SHEET NO. 1 OF 13

# CITY OF YPSILANTI WASHTENAW COUNTY, MICHIGAN BALLARD LOT REHABILITATION

## CITY OF YPSILANTI CITY COUNCIL

**NICOLE BROWN**  
• MAYOR •

**STEVEN WILCOXEN**  
• MAYOR PRO-TEM •

**Me'CHELLE KING**  
**PATRICK McLEAN**

**DESIRAÉ SIMMONS**  
**AMBER FELLOWS**  
**ROLAND TOOSON**  
• COUNCIL MEMBERS •

**ANDREW HELLENGA**  
• CITY MANAGER •

INDEX OF SHEETS	
SHEET NO.	DESCRIPTION
2	COVER
3	NOTES & DETAILS
4	LEGEND
5	REMOVAL AND CONSTRUCTION PLAN
6	PAVEMENT MARKINGS PLAN

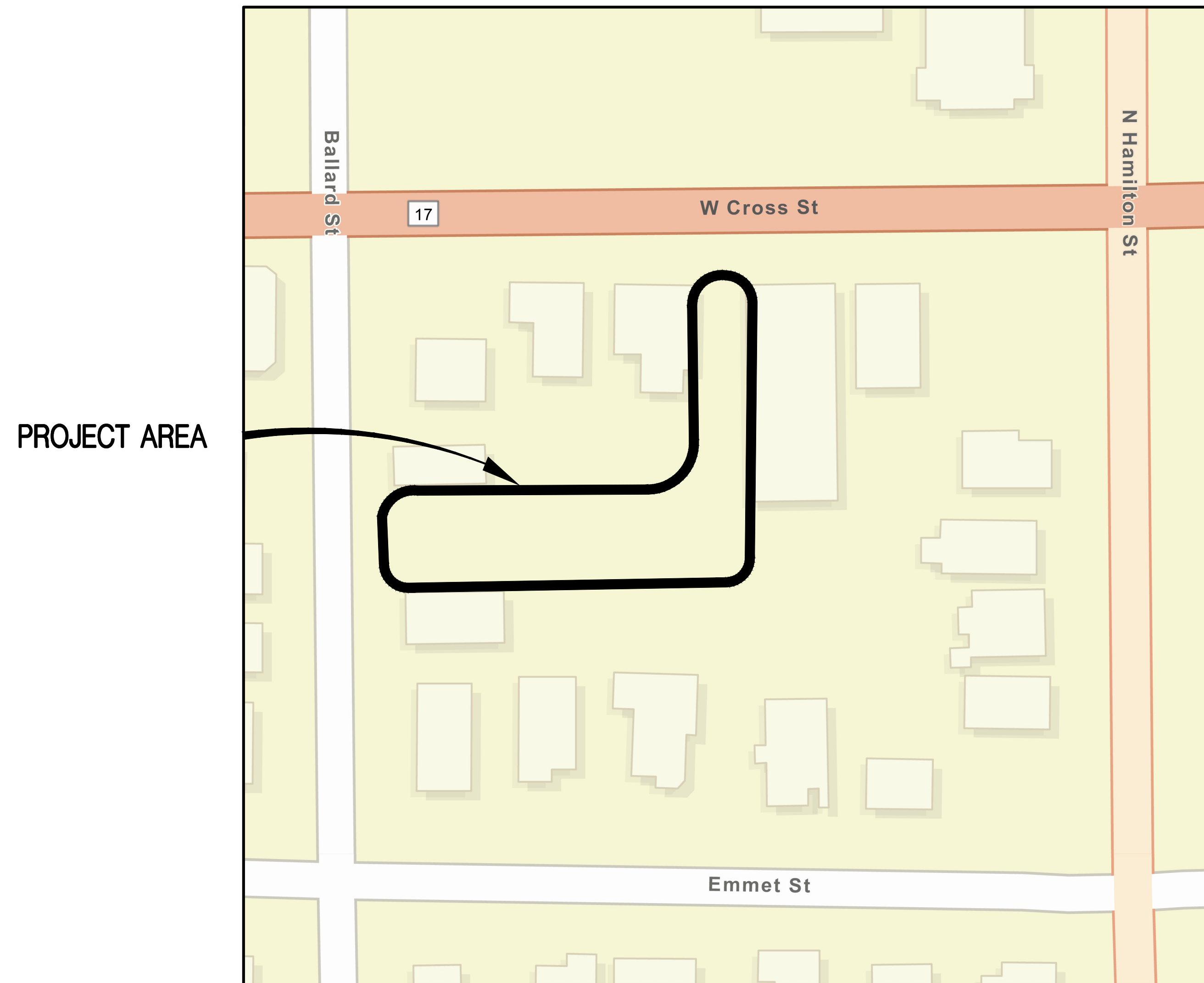

N  
↑  
**LOCATION MAP**  
N.T.S.

GENERAL PROVISIONS

THE IMPROVEMENTS COVERED BY THESE PLANS SHALL BE DONE IN ACCORDANCE WITH THE PROPOSAL AND ACCOMPANYING SPECIFICATIONS FOR THIS PROJECT INCLUDING THE 2020 MICHIGAN DEPARTMENT OF TRANSPORTATION STANDARD SPECIFICATIONS FOR CONSTRUCTION, 2025 MICHIGAN MANUAL OF UNIFORM TRAFFIC CONTROL DEVICES, AND THE MICHIGAN DEPARTMENT OF TRANSPORTATION LOCAL AGENCY PROGRAMS GUIDELINES FOR GEOMETRICS DATED 7-24-2017.

THE LOCATION OF ALL PUBLIC UTILITIES SHOWN ON THESE PLANS IS TAKEN FROM THE BEST AVAILABLE DATA. THE CITY OF YPSILANTI WILL NOT BE RESPONSIBLE FOR ANY OMISSION OR VARIATION FROM THE LOCATIONS SHOWN. PURSUANT TO ACTS 173 & 174 OF THE P.A. OF 2013, AS A CONDITION OF THIS CONTRACT, NOTICE SHALL BE GIVEN TO MISS DIG PRIOR TO UNDERGROUND WORK TO BE PERFORMED IN ACCORDANCE WITH THIS CONTRACT, PHONE (800) 482-7171 (OR 811). UTILITY SERVICE CONNECTIONS ARE NOT SHOWN ON THE PLANS AND ARE NOT THE RESPONSIBILITY OF THE CITY OF YPSILANTI.

THE ELEVATIONS SHOWN ON THESE PLANS ARE BASED ON NAVD 1988 VERTICAL DATUM.

## LOCATION AND SCOPE OF PROJECT

THE PROJECT SITE IS LOCATED IN THE CITY OF YPSILANTI IN WASHTENAW COUNTY, MICHIGAN. THE WORK TO BE COMPLETED UNDER THIS CONTRACT INCLUDES THE FURNISHING OF ALL MATERIALS, EQUIPMENT, AND LABOR NECESSARY TO CONSTRUCT THE PROPOSED PARKING LOT IMPROVEMENTS.

## GENERAL NOTES

- IT IS THE INTENTION OF THESE PLANS TO CONSTRUCT ALL WORK IN ACCORDANCE WITH APPLICABLE REQUIREMENTS OF THE CITY OF YPSILANTI AND THE PLANS AND SPECIFICATIONS REFERENCED HEREIN. WHERE THERE IS A CONFLICT BETWEEN ANY OF THE AFOREMENTIONED SPECIFICATIONS AND THE PERMIT REQUIREMENTS OF THE AGENCY CONTROLLING THE RESPECTIVE UTILITY OR RIGHTS-OF-WAY, THE MORE RESTRICTIVE SHALL GOVERN.
- THE CONTRACTOR AND THEIR SUBCONTRACTORS SHALL ATTEND A PRE-CONSTRUCTION MEETING AT A TIME AND PLACE ARRANGED BY THE CITY OF YPSILANTI AND THE ENGINEER AT WHICH THE AFFECTED UTILITY COMPANIES AND GOVERNMENT AGENCY REPRESENTATIVES WILL BE PRESENT.
- AFTER A PRE-CONSTRUCTION MEETING IS HELD, THE CONTRACTOR SHALL NOTIFY THE ENGINEER, A MINIMUM OF THREE (3) WORKING DAYS PRIOR TO THE START OF CONSTRUCTION FOR INSPECTION.
- LOCATIONS AND ELEVATIONS OF EXISTING UNDERGROUND UTILITIES AS SHOWN ON THE PLANS ARE APPROXIMATE. NO GUARANTEE IS EITHER EXPRESSED OR IMPLIED AS TO THE COMPLETENESS OR ACCURACY THEREOF. THE CONTRACTOR SHALL BE EXCLUSIVELY RESPONSIBLE FOR DETERMINING AND VERIFYING THE LOCATION, DEPTH, AND ELEVATION OF EXISTING UTILITIES, AND PROPOSED UTILITIES CROSSING THE CONSTRUCTION AREA PRIOR TO START OF CONSTRUCTION. CONTRACTOR SHALL NOTIFY ENGINEER IF ANY CONFLICTS ARE APPARENT OR IF LOCATIONS AND DEPTHS DIFFER SIGNIFICANTLY FROM THE PLANS.
- ALL PROPERTIES OR FACILITIES IN THE SURROUNDING AREAS, PUBLIC OR PRIVATE, DESTROYED OR OTHERWISE DAMAGED BY THE CONTRACTOR'S OPERATIONS SHALL BE REPLACED OR REPAIRED TO THE SATISFACTION OF THE AUTHORITY HAVING JURISDICTION OF THE PROPERTY OR FACILITY BY THE CONTRACTOR AT THEIR OWN EXPENSE.
- CONTRACTOR SHALL PROVIDE AND MAINTAIN ALL NECESSARY BARRICADES AND TRAFFIC CONTROL DEVICES REQUIRED BY THE WASHTENAW COUNTY ROAD COMMISSION, CITY OF YPSILANTI, OR OTHER AGENCIES HAVING JURISDICTION.
- ALL ROADS, ROAD SHOULDERS, AND DRIVEWAYS DISTURBED BY THE CONTRACTOR'S OPERATIONS SHALL BE RESTORED AS CALLED FOR ON THE PLANS AND PAID FOR AT THE UNIT PRICES BUD.

## SAWCUTS

THE CONTRACTOR SHALL SAWCUT THE EXISTING CONCRETE AND/OR HMA PAVEMENT AND DRIVEWAYS TO THE LIMITS OF PROPOSED CONSTRUCTION, TO MAKE A NEAT AND SMOOTH CONNECTION TO THE EXISTING PAVEMENT OR DRIVEWAY AS REQUIRED AND DIRECTED. THIS WORK WILL NOT BE PAID FOR SEPARATELY, BUT WILL BE CONSIDERED INCLUDED IN THE CONTRACT UNIT PRICE BID FOR OTHER REMOVAL ITEMS.

## DUST CONTROL

THE CONTRACTOR SHALL BE RESPONSIBLE FOR DUST CONTROL ON THIS PROJECT. IT SHALL BE UNDERSTOOD THAT THIS IS A RESIDENTIAL NEIGHBORHOOD. KEEPING DUST TO A MINIMUM IS HIGH PRIORITY AND WILL BE EXPECTED TO BE MAINTAINED ON A REGULAR BASIS. DUST CONTROL WILL BE CONSIDERED INCIDENTAL TO THE PROJECT.

## PROTECTION OF EXISTING PAVEMENT

PAVEMENT DAMAGED BY THE CONTRACTOR IN AREAS WHERE PAVEMENT REMOVAL IS NOT SHOWN ON THE PLANS SHALL BE REMOVED AND REPLACED IN ACCORDANCE WITH THE CROSS SECTIONS PROVIDED IN THE PLANS. REMOVAL AND REPLACEMENT OF THESE AREAS SHALL BE AT THE CONTRACTOR'S EXPENSE.

## CLEANING PAVEMENT

BEFORE PLACING ANY HMA MIXTURE, THE SURFACE OF THE EXISTING PAVEMENT INCLUDING ALL CURBS, CRACKS, JOINTS, AND THE SURFACE OF THE NEW BASE AND LEVELING COURSES SHALL BE THOROUGHLY CLEANED OF ALL DEBRIS AND DIRT. THIS WORK WILL NOT BE PAID FOR SEPARATELY AND WILL BE CONSIDERED INCLUDED IN THE CONTRACT UNIT PRICE BID FOR OTHER HMA ITEMS.

## EXISTING CASTINGS

EXISTING UNDAMAGED CASTINGS DAMAGED BY THE CONTRACTOR SHALL BE REPLACED BY THE CONTRACTOR AT THEIR OWN EXPENSE IN KIND OR AS DETERMINED BY THE ENGINEER.

## PAVEMENT CORES

THE PAVEMENT CORES REPRESENT POINT INFORMATION. NO INFERENCE SHOULD BE MADE THAT SUBSURFACE OR PAVEMENT CONDITIONS ARE THE SAME AT OTHER LOCATIONS. THE PAVEMENT CORE LOGS CAN BE FOUND IN APPENDIX A.

## MISCELLANEOUS

THE CONTRACTOR SHALL BE RESPONSIBLE FOR ANY DAMAGE TO THE PROPERTY BEYOND THE PROJECT LIMIT, INCLUDING EXISTING FENCING, GUARDRAIL, LAWN, TREES AND SHRUBBERY. ALL AREAS DISTURBED BY THE CONTRACTOR AND/OR HIS/HER SUBCONTRACTOR(S) BEHIND THE NORMAL CONSTRUCTION LIMITS OF THIS PROJECT SHALL BE SODDED OR SEEDED AS SPECIFIED OR DIRECTED BY THE ENGINEER. NO ADDITIONAL PAYMENT OR COMPENSATION WILL BE ALLOWED FOR THIS ACTIVITY.

## UTILITIES

THE CONTRACTOR SHALL TAKE ALL NECESSARY PRECAUTIONS TO PROTECT UTILITIES FROM DAMAGE. THESE PRECAUTIONS ARE TO BE INCLUDED IN THE CONTRACT PAY ITEMS AND WILL NOT BE PAID FOR SEPARATELY.

FOR PROTECTION OF UNDERGROUND UTILITIES AND IN CONFORMANCE WITH PUBLIC ACT 174, THE CONTRACTOR SHALL DIAL 1-800-482-7171 A MINIMUM OF THREE FULL WORKING DAYS, EXCLUDING SATURDAYS, SUNDAYS AND HOLIDAYS, PRIOR TO BEGINNING EACH EXCAVATION IN AREAS WHERE PUBLIC UTILITIES HAVE NOT BEEN PREVIOUSLY LOCATED. MEMBERS WILL BE ROUTINELY NOTIFIED. THIS DOES NOT RELIEVE THE CONTRACTOR OF THE RESPONSIBILITY OF NOTIFYING UTILITY OWNERS WHO MAY NOT BE A PART OF THE "MISS DIG" ALERT SYSTEM. UTILITY LOCATIONS SHOWN ON THE PLANS ARE ONLY APPROXIMATE AND SHOULD BE LOCATED IN THE FIELD BEFORE EXCAVATING IN THE AREA.

THE FOLLOWING UTILITY COMPANIES HAVE FACILITIES WITHIN THE PROJECT LIMITS:

**INTERNET & TELEPHONE**  
AT&T  
550 S MAPLE ROAD  
ANN ARBOR, MI 48103  
ATTN: GARY CLINTON  
PH: 734-996-2135

54 N MILL STREET  
PONTIAC, MI 48342  
ATTN: C. ANIKA ESTES  
PH: 248-454-2998  
EMAIL: CE3239@ATT.COM

**CABLE TELEVISION**  
COMCAST  
25626 TELEGRAPH ROAD  
SOUTHFIELD, MI 48034  
ATTN: JEFF DOBIES  
PH: 734-359-1669

ATTN: CRAIG PUDAS  
PH: 248-809-2715  
EMAIL: CRAIG\_PUDAS@CABLE.COMCAST.COM

**GAS & ELECTRIC**  
DTE ENERGY  
982 BROADWAY STREET  
ANN ARBOR, MI 48105  
ATTN: JAMES BRENNAN JR  
PH: 1-800-338-0178  
ATTN: SARA KIPP  
PH: 313-407-5364  
PH: 248-318-7839

**WATER AND SANITARY**  
YPSILANTI COMM UTIL AUTH  
2777 STATE ROAD  
YPSILANTI, MI 48198  
ATTN: SEAN KNAPP  
PH: 734-484-4600  
EMAIL: MSTAKING@YCUA.ORG

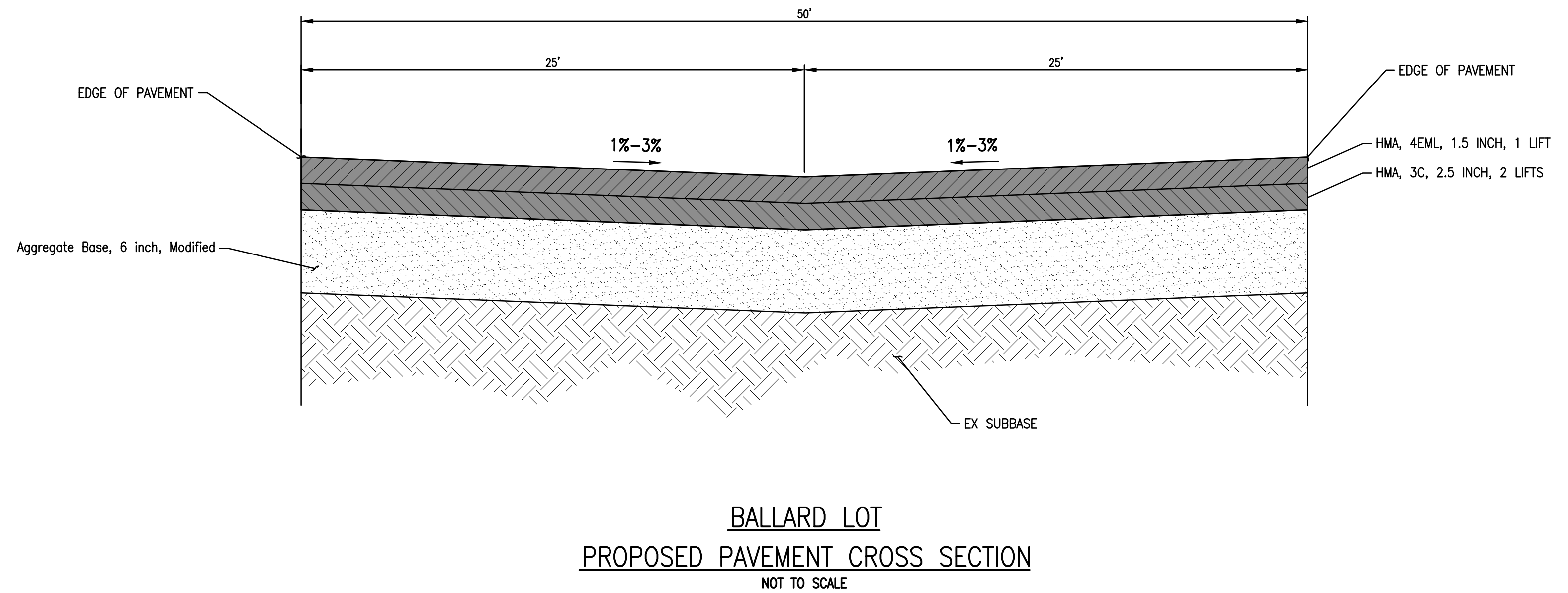
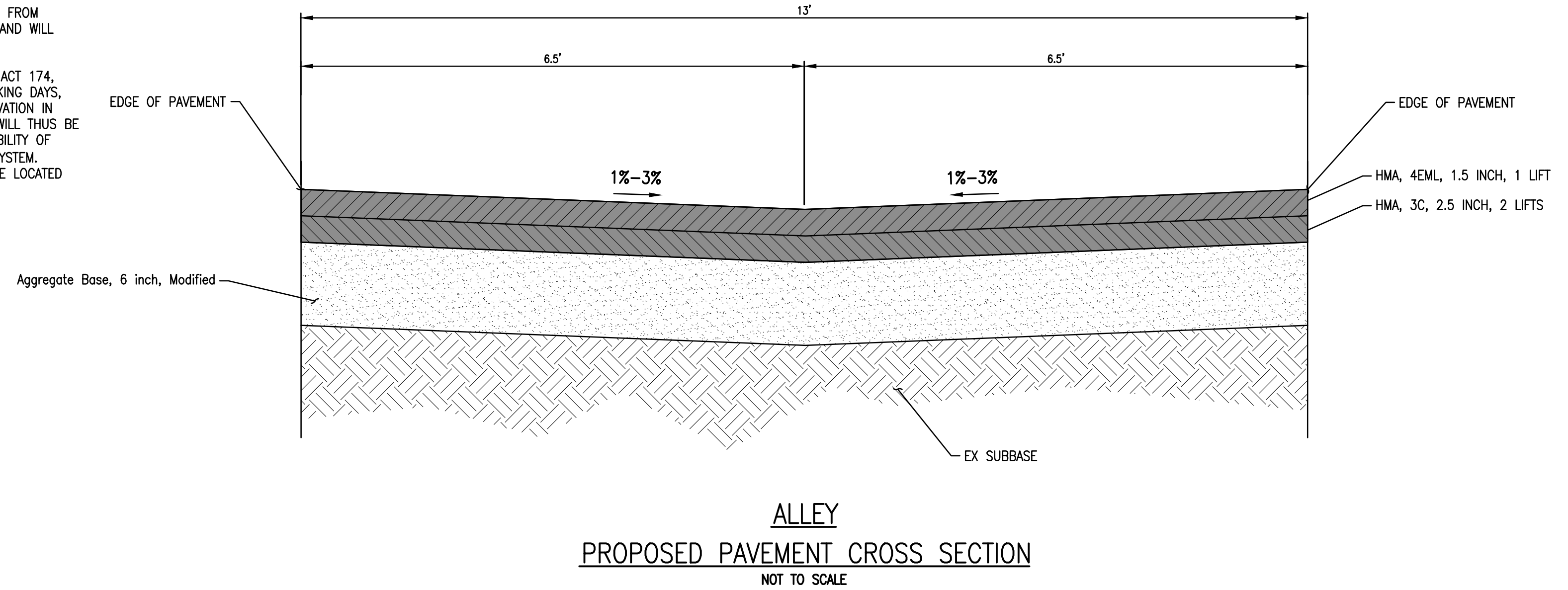

QUANTITIES THIS SHEET		
TOTAL	UNIT	DESCRIPTION
1	LSUM	Maintenance of Traffic
1	LSUM	Mobilization, Max 10%
500	Dir	SESC Permit Allowance

PERMANENT HMA APPLICATION CHART					
SYMBOL	PAY ITEM	RATE (LB/SYD)	DEPTH (IN)	PERFORMANCE GRADE	REMARKS
4EML	HMA, 4EML	165 LB	1.5	58-28	TOP COURSE
3C	HMA, 3C	275 LB	2.5	58-28	BASE COURSE
HP	HAND PATCHING	VARIES	VARIES	58-28	HMA, 4EML - MAX 2" PER LIFT
-	-	0.05 - 0.15 GAL/SYD	-	TYPE SS-1h	BOND COAT - TO BE APPLIED BETWEEN EACH LIFT OF NEW PERMANENT HMA & EACH LIFT OF NEW TEMPORARY HMA (TYP)

**NOTE:**  
THE APPLICATION RATE MINIMUM OF 220 LBS/YD2 FOR MIX NUMBER 4 PER TABLE 501-4 OF THE MDOT 2020 STANDARD SPECIFICATIONS FOR CONSTRUCTION DOES NOT APPLY TO THE 4EML COURSE.

**WATER & SEWER UTILITY SYMBOLS**

**EXISTING**

- <sub>ST</sub> STORM MANHOLE
- SQUARE CATCH BASIN
- ⊕ ROUND CATCH BASIN
- == CULVERT
- ⊕ CULVERT W/O END SECTION
- ) CULVERT W/END SECTION
- <sub>S</sub> SANITARY MANHOLE
- ⊙ CLEAN OUT
- ⊗<sub>GW</sub> GATE VALVE & WELL
- GATE VALVE & BOX
- ⊕<sub>W</sub> WATER STOP BOX
- ⊕ FIRE HYDRANT
- ⊕<sub>MP</sub> METER PIT
- ⊕ WATER METER
- ⊕<sub>SH</sub> SPRINKLER HEAD
- ⊕<sub>W</sub> IRRIGATION VALVE

**PROPOSED**

- STORM MANHOLE
- INLET/CATCH BASIN
- ⊕ CULVERT W/O END SECTION
- ) CULVERT END SECTION
- SANITARY MANHOLE
- ⊗<sub>GW&W</sub> GATE VALVE & WELL
- ⊗<sub>GW&B</sub> GATE VALVE & BOX
- ⊗<sub>TSV&W</sub> TAPPING SLEEVE VALVE & WELL
- ⊗<sub>TSV&B</sub> TAPPING SLEEVE VALVE & BOX
- ⊕ FIRE HYDRANT

**REAL ESTATE SYMBOLS**

- ↔ CONTIGUOUS PROPERTY SYMBOL
- ⊗<sub>XXX</sub> PARCEL NUMBER BOX
- ⊗<sub>XXX</sub> NO ROW IMPACTS

**MISCELLANEOUS UTILITY SYMBOLS**

**EXISTING**

- ↘ GUY WIRE
- ⊕<sub>GP</sub> GUY POLE
- ⊕<sub>U</sub> UTILITY POLE
- ⊕<sub>U</sub> UTILITY POLE W/LIGHT
- ⊕ LIGHT/DECOR LAMP POLE
- ⊕ FLOOD LIGHT
- ⊕ GAS VALVE
- ⊕ GAS VENT
- ⊕ GAS METER
- ⊕ GAS RISER
- ⊕ TRAFFIC SIGNAL
- ⊕ PEDESTRIAN RISER
- ⊕ TRANSFORMER PAD
- ⊕ PRIVATE UTILITY MANHOLE
- ⊕<sub>R</sub> RAILROAD CROSSING
- ⊕ ELECTRIC METER
- ⊕ PB PHONE BOOTH
- ⊕ TS TRAFFIC SIGNAL CONTROLLER
- ⊕ HAND HOLE
- ⊕ ELECTRIC RISER
- ⊕ TELEPHONE RISER
- ⊕ CABLE TV RISER
- ⊕ MONITORING WELL
- UNDERGROUND MARKER

**MISCELLANEOUS SYMBOLS**

**EXISTING**

- ⊕ RIPRAP
- ↑ SIGN
- FLOW DIRECTION
- ⊕ STUMP
- ⊕ WETLAND
- ⊕ CONIFEROUS TREE } CL 1 1" TO 5"
- ⊕ DECIDUOUS TREE } CL 2 6" TO 17"
- ⊕ CONIFEROUS SHRUB } CL 3 18" TO 35"
- ⊕ DECIDUOUS SHRUB } CL 4 36" AND UP
- ⊕<sub>SB#</sub> SOIL BORING
- ⊕ SECTION CORNER
- MONUMENT
- IRON ROD/PIPE
- ⊕ PK PK NAIL
- <sub>BM#</sub> BENCHMARK
- ⊕<sub>TP#</sub> TRAVERSE POINT
- ⊕ MAIL/NEWSPAPER BOX
- ⊕ FLAG POLE
- POST

**HAZARDOUS OR FLAMMABLE MATERIAL** USED WITH UNDERGROUND GAS & ELECTRICAL LINES

**CAUTION - CRITICAL UNDERGROUND UTILITY** USED WITH TELEPHONE & FIBER OPTIC LINES

**PROPOSED**

- ⊕ RIPRAP
- ↑, ↑, ↑, ↑, ↑, ↑ SIGN
- FLOW DIRECTION
- ⊕<sub>WM</sub> STRUCTURE NUMBER WM
- ⊕<sub>SAN</sub> SAN
- ⊕<sub>STM</sub> STM
- ⊕ ADA SIDEWALK RAMP
- ⊕ PAVEMENT REMOVE AND REPLACE

**UTILITY PATTERN**

**EXISTING**

- ELEC --- ELECTRICAL \*
- 6" (COMPANY) GAS --- GAS/OIL
- (COMPANY) CABLE/TEL --- CABLE/TELEPHONE \*
- FIBER OPTIC --- FIBER OPTIC \*
- 12" WM --- WATER
- 12" SAN --- SANITARY
- 12" STM --- STORM

**PROPOSED**

- 12" --- STORM/SANITARY/WATER
  - 12" --- PRIMARY UTILITY WILL HAVE A CONTINUOUS LINESYLE, WITH THE SECONDARY UTILITY MATCHING ITS RESPECTIVE EXISTING UTILITY LINESYLE
- \*O.H. = OVERHEAD , U.G. = UNDERGROUND

**ROW PATTERN**

**EXISTING**

- ROW --- ROW
- SECTION --- SECTION
- PROPERTY/PARCEL --- PROPERTY/PARCEL

**PROPOSED**

- ROW --- ROW

**TOPO PATTERN**

**EXISTING**

- HEDGE/TREE --- HEDGE/TREE
- FENCE --- FENCE
- GUARDRAIL --- GUARDRAIL
- CENTERLINE OF DITCH --- CENTERLINE OF DITCH
- RAILROAD --- RAILROAD
- WETLAND/EDGE OF WATER --- WETLAND/EDGE OF WATER

**PROPOSED**

- GRADING LIMIT (SLOPE STAKE) --- GRADING LIMIT (SLOPE STAKE)
- CENTERLINE OF DITCH --- CENTERLINE OF DITCH
- GUARDRAIL --- GUARDRAIL
- FENCE --- FENCE

**REMOVAL LEGEND**

- ▨ SIDEWALK REMOVAL
- ▨ HMA SURFACE REMOVAL
- ▨ PAVEMENT REMOVAL
- ▨ COLD MILLING HMA SURFACE
- ▨ HMA BASE CRUSHING AND SHAPING
- ▨ EXCAVATION, EARTH, MODIFIED
- CURB AND GUTTER, REM
- ⊗ TREE, REM
- S-XXXXXX SALVAGE
- B-XXXXXX BULKHEAD
- A-XXXXXX ABANDON
- R-XXXXXX REMOVE
- ADJ-XXXXXX ADJUST
- REL-XXXXXX RELOCATE
- REC-XXXXXX RECONSTRUCT
- R B/O-XXXXXX REMOVE BY OTHERS
- ADJ B/O-XXXXXX ADJUST BY OTHERS
- REL B/O-XXXXXX RELOCATE BY OTHERS

**IF NECESSARY FOR CLARITY**

- ⊕ SALVAGE
- ⊕ BULKHEAD
- ⊕ ABANDON
- ⊕ CLEARING
- ⊕ REMOVE
- REL RELOCATE
- REC RECONSTRUCT
- REL B/O RELOCATE BY OTHERS
- ADJ B/O ADJUST BY OTHERS

**SPECIAL LEGEND**



ISSUED FOR CHANGE ORDER NO 1 04/07/2026 DATE

REVISION DESCRIPTION

5/29/2025 BID SUBMITTAL 09/04/2025 ADDENDUM NO 1

04/07/2026 CHANGE ORDER NO 1

PROJECT NUMBER PM RU 0094-25-0070

CITY OF YPSILANTI

BALLARD LOT REHABILITATION

YPSILANTI, MI

LEGEND

# WEST CROSS STREET (65' R.O.W.)

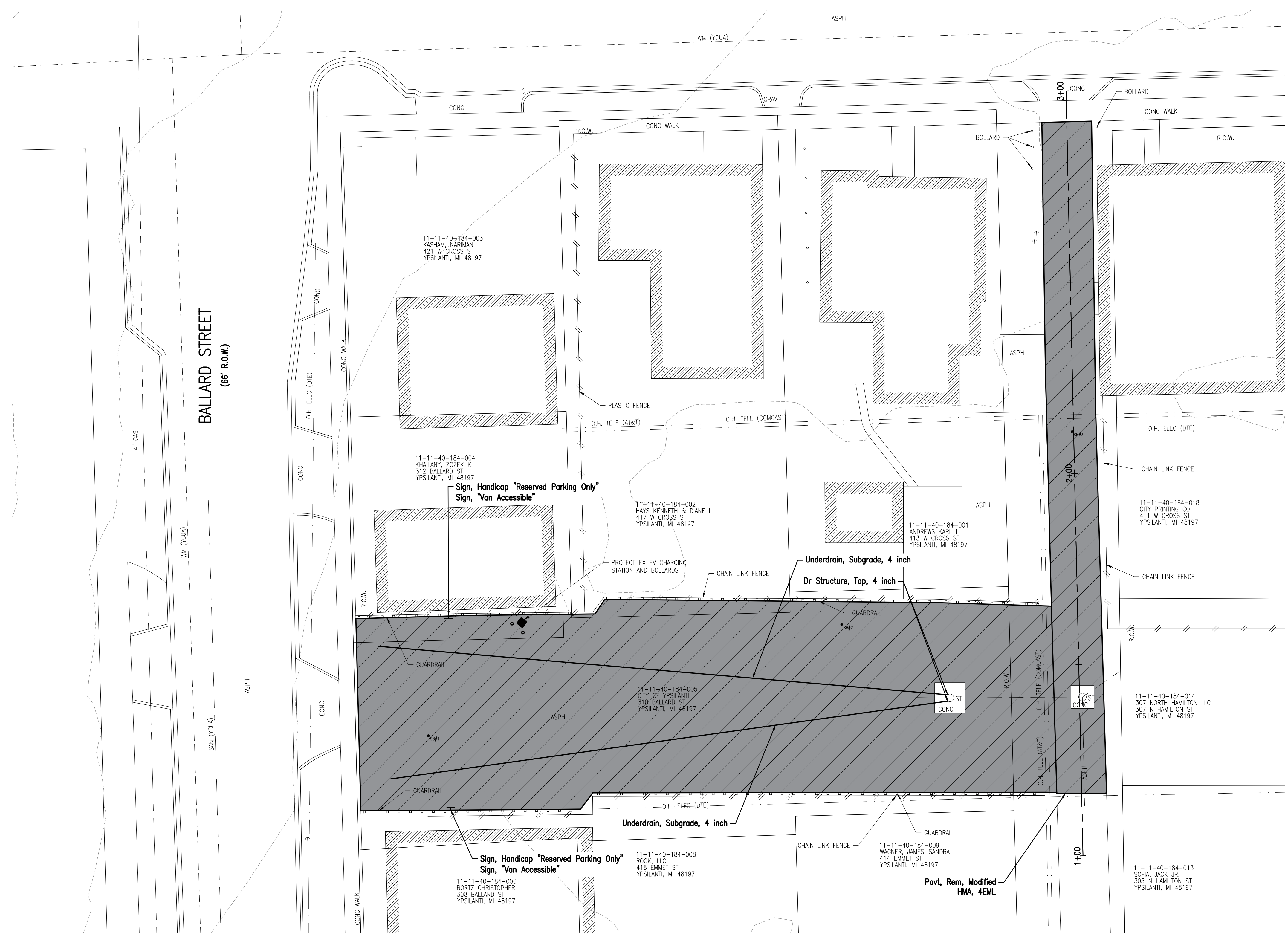
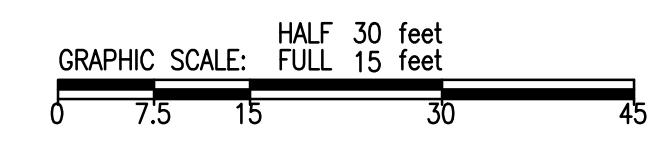

TOTAL	UNIT	DESCRIPTION
1380	Syd	Pavt, Rem, Modified
2	Ea	Erosion Control, Inlet Protection, Fabric Drop
1380	Syd	Aggregate Base, 6 inch, Modified
2	Ea	Dr Structure, Top, 4 inch
2	Ea	Utility Structure Cover, Adj, Case 1
300	Ft	Underdrain, Subgrade, 4 inch
10	Ton	Hand Patching
190	Ton	HMA, 3C
114	Ton	HMA, 4EML
2	Ea	Sign, "Van Accessible"
2	Ea	Sign, Handicap "Reserved Parking Only"

- NOTES:
- CONTRACTOR SHALL PROVIDE POSITIVE DRAINAGE ON ASPHALT SURFACE. INLETS SHALL BE THE LOW POINT IN THE PAVED AREA.
  - ADA SPACES SHALL HAVE A MAXIMUM SLOPE OF 2% IN ALL DIRECTIONS.

ISSUED FOR:	CHANGE ORDER NO. 1	DATE
REVISION	DESCRIPTION	DATE
8/29/2025	BID SUBMITTAL	
09/04/2025	ADDENDUM NO. 1	
04/07/2026	CHANGE ORDER NO. 1	

CITY OF YPSILANTI  
BALLARD LOT REHABILITATION  
YPSILANTI, MI  
REMOVAL AND CONSTRUCTION PLAN



Know what's below.  
Call before you dig.

# WEST CROSS STREET (65' R.O.W.)

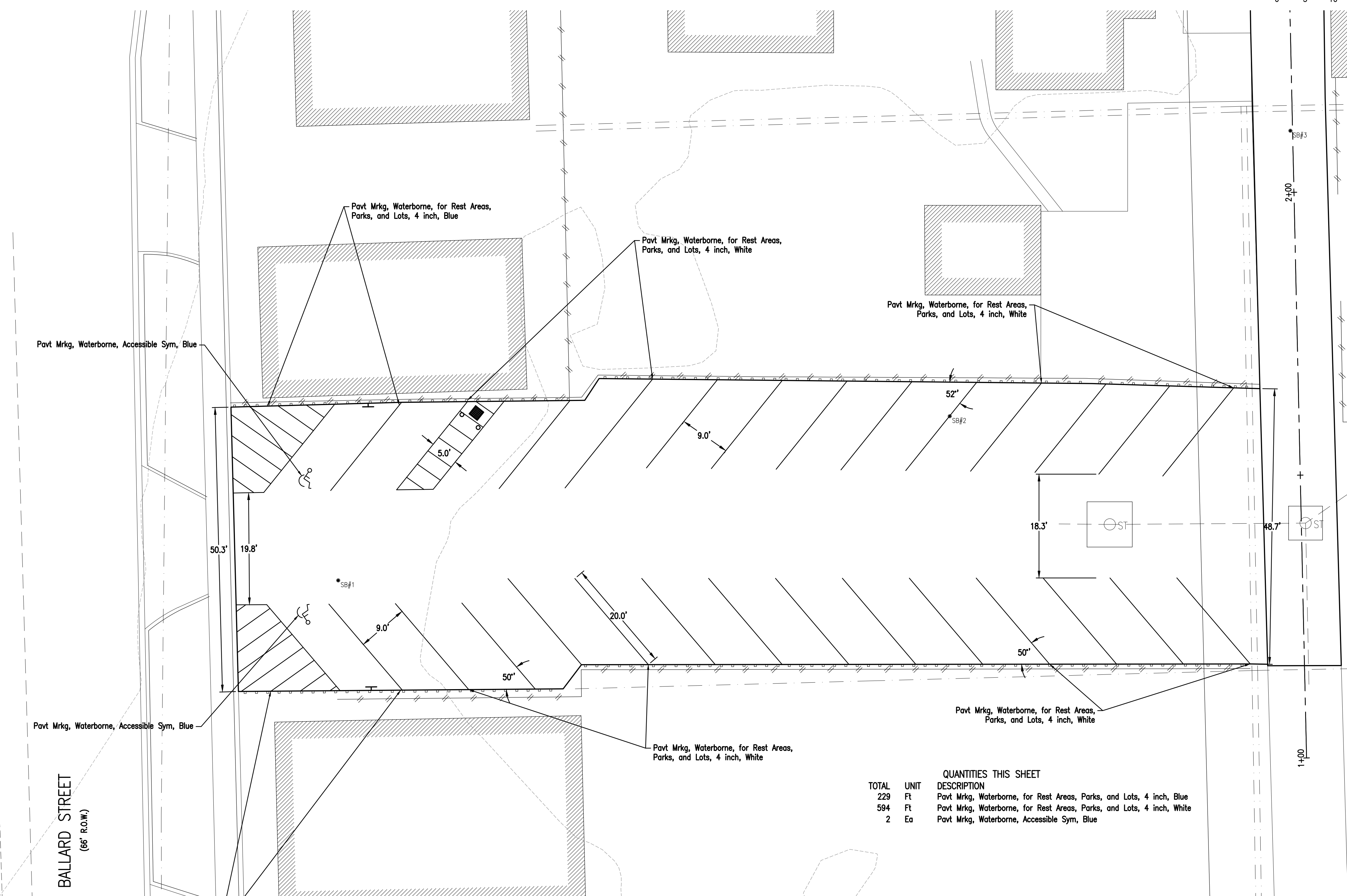
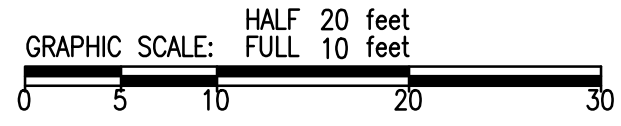

TOTAL	UNIT	DESCRIPTION
229	Ft	Pavt Mrkg, Waterborne, for Rest Areas, Parks, and Lots, 4 inch, Blue
594	Ft	Pavt Mrkg, Waterborne, for Rest Areas, Parks, and Lots, 4 inch, White
2	Ea	Pavt Mrkg, Waterborne, Accessible Sym, Blue

ISSUED FOR	CHANGE ORDER NO 1	DATE
5/26/2025 BID SUBMITTAL		04/07/2026
09/04/2025 ADDENDUM NO 1		
04/07/2026 CHANGE ORDER NO 1		

PROJECT NUMBER: 0094-25-2070  
 PM: RU  
 CITY OF YPSILANTI  
 BALLARD LOT REHABILITATION  
 YPSILANTI, MI  
 PAVEMENT MARKINGS PLAN



Know what's below.  
Call before you dig.

DRAWING PATH: P:\000\_0100\09425070\_Ballard\_Lot\_Rehabilitation\Drawings\CP\PM\0507\PMAS.dwg April 14, 2026 - 2:20 PM

COPYRIGHT 2026 OHM. ALL DRAWINGS AND WRITTEN MATERIALS APPEARING HEREIN CONSTITUTE THE ORIGINAL AND UNPUBLISHED WORK OF OHM AND THE SAME MAY NOT BE DUPLICATED, DISTRIBUTED, OR DISCLOSED WITHOUT PRIOR WRITTEN CONSENT OF OHM

# CITY OF YPSILANTI WASHTENAW COUNTY, MICHIGAN FREIGHTHOUSE LOT REHABILITATION

## CITY OF YPSILANTI CITY COUNCIL

**NICOLE BROWN**  
• MAYOR •

**STEVEN WILCOXEN**  
• MAYOR PRO-TEM •

**Me'CHELLE KING**  
**PATRICK McLEAN**  
**DESIRAÉ SIMMONS**  
**AMBER FELLOWS**  
**ROLAND TOOSON**  
• COUNCIL MEMBERS •

**ANDREW HELLENGA**  
• CITY MANAGER •

INDEX OF SHEETS	
SHEET NO.	DESCRIPTION
7	COVER
8	NOTES & DETAILS
9	LEGEND
10	REMOVAL PLAN
11	CONSTRUCTION PLAN
12	PAVEMENT MARKINGS PLAN
13	ADA GRADING PLAN

PROJECT AREA

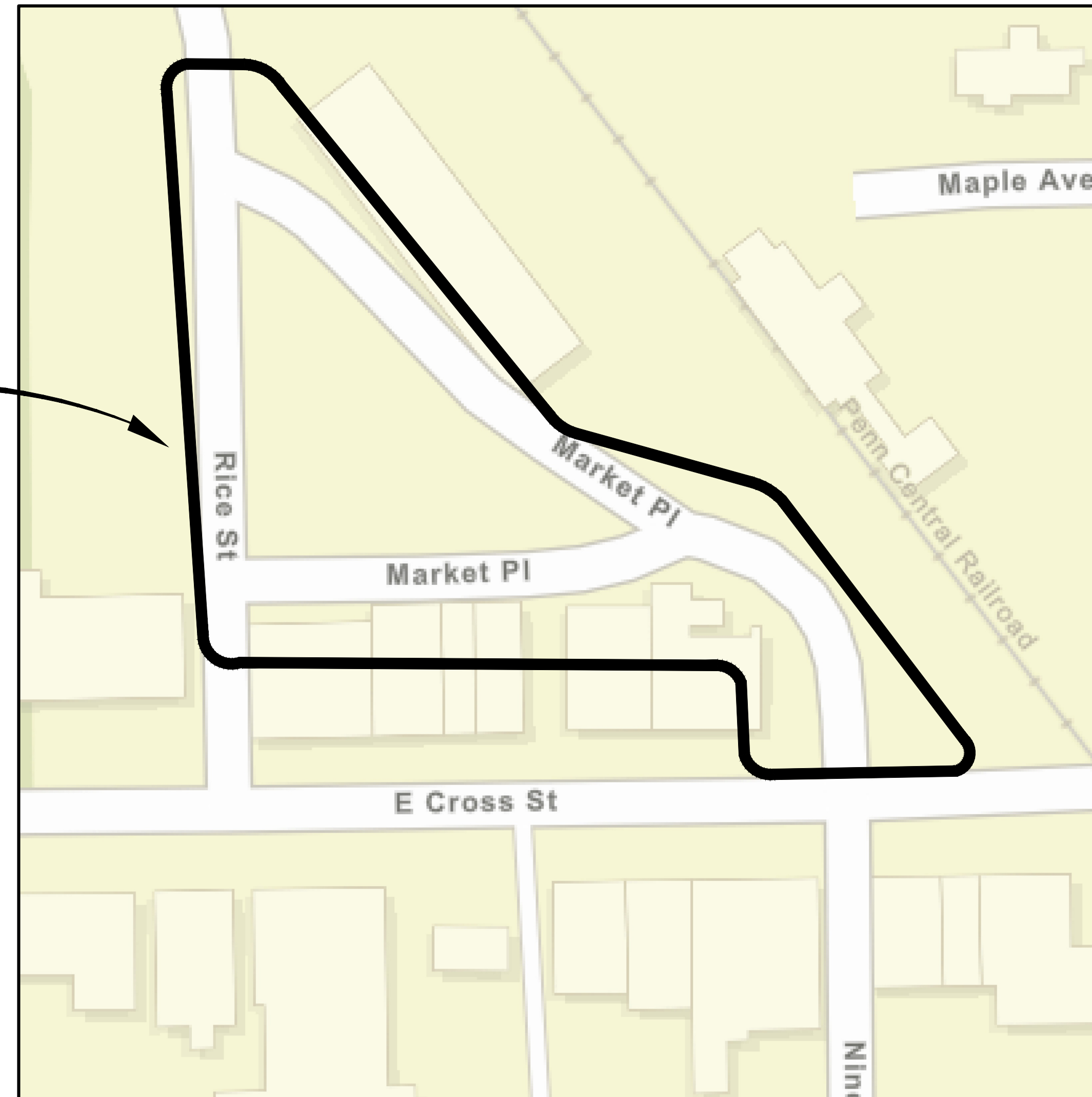

N  
↑  
**LOCATION MAP**  
N.T.S.

GENERAL PROVISIONS

THE IMPROVEMENTS COVERED BY THESE PLANS SHALL BE DONE IN ACCORDANCE WITH THE PROPOSAL AND ACCOMPANYING SPECIFICATIONS FOR THIS PROJECT INCLUDING THE 2020 MICHIGAN DEPARTMENT OF TRANSPORTATION STANDARD SPECIFICATIONS FOR CONSTRUCTION, 2025 MICHIGAN MANUAL OF UNIFORM TRAFFIC CONTROL DEVICES, AND THE MICHIGAN DEPARTMENT OF TRANSPORTATION LOCAL AGENCY PROGRAMS GUIDELINES FOR GEOMETRICS DATED 7-24-2017.

THE LOCATION OF ALL PUBLIC UTILITIES SHOWN ON THESE PLANS IS TAKEN FROM THE BEST AVAILABLE DATA. THE CITY OF YPSILANTI WILL NOT BE RESPONSIBLE FOR ANY OMISSION OR VARIATION FROM THE LOCATIONS SHOWN. PURSUANT TO ACTS 173 & 174 OF THE P.A. OF 2013, AS A CONDITION OF THIS CONTRACT, NOTICE SHALL BE GIVEN TO MISS DIG PRIOR TO UNDERGROUND WORK TO BE PERFORMED IN ACCORDANCE WITH THIS CONTRACT, PHONE (800) 482-7171 (OR 811). UTILITY SERVICE CONNECTIONS ARE NOT SHOWN ON THE PLANS AND ARE NOT THE RESPONSIBILITY OF THE CITY OF YPSILANTI.

THE ELEVATIONS SHOWN ON THESE PLANS ARE BASED ON NAVD 1988 VERTICAL DATUM.

## LOCATION AND SCOPE OF PROJECT

THE PROJECT SITE IS LOCATED IN THE CITY OF YPSILANTI IN WASHTENAW COUNTY, MICHIGAN. THE WORK TO BE COMPLETED UNDER THIS CONTRACT INCLUDES THE FURNISHING OF ALL MATERIALS, EQUIPMENT, AND LABOR NECESSARY TO CONSTRUCT THE PROPOSED PARKING LOT IMPROVEMENTS.

## GENERAL NOTES

- IT IS THE INTENTION OF THESE PLANS TO CONSTRUCT ALL WORK IN ACCORDANCE WITH APPLICABLE REQUIREMENTS OF THE CITY OF YPSILANTI AND THE PLANS AND SPECIFICATIONS REFERENCED HEREIN. WHERE THERE IS A CONFLICT BETWEEN ANY OF THE AFOREMENTIONED SPECIFICATIONS AND THE PERMIT REQUIREMENTS OF THE AGENCY CONTROLLING THE RESPECTIVE UTILITY OR RIGHTS-OF-WAY, THE MORE RESTRICTIVE SHALL GOVERN.
- THE CONTRACTOR AND THEIR SUBCONTRACTORS SHALL ATTEND A PRE-CONSTRUCTION MEETING AT A TIME AND PLACE ARRANGED BY THE CITY OF YPSILANTI AND THE ENGINEER AT WHICH THE AFFECTED UTILITY COMPANIES AND GOVERNMENT AGENCY REPRESENTATIVES WILL BE PRESENT.
- AFTER A PRE-CONSTRUCTION MEETING IS HELD, THE CONTRACTOR SHALL NOTIFY THE ENGINEER, A MINIMUM OF THREE (3) WORKING DAYS PRIOR TO THE START OF CONSTRUCTION FOR INSPECTION.
- LOCATIONS AND ELEVATIONS OF EXISTING UNDERGROUND UTILITIES AS SHOWN ON THE PLANS ARE APPROXIMATE. NO GUARANTEE IS EITHER EXPRESSED OR IMPLIED AS TO THE COMPLETENESS OR ACCURACY THEREOF. THE CONTRACTOR SHALL BE EXCLUSIVELY RESPONSIBLE FOR DETERMINING AND VERIFYING THE LOCATION, DEPTH, AND ELEVATION OF EXISTING UTILITIES, AND PROPOSED UTILITIES CROSSING THE CONSTRUCTION AREA PRIOR TO START OF CONSTRUCTION. CONTRACTOR SHALL NOTIFY ENGINEER IF ANY CONFLICTS ARE APPARENT OR IF LOCATIONS AND DEPTHS DIFFER SIGNIFICANTLY FROM THE PLANS.
- ALL PROPERTIES OR FACILITIES IN THE SURROUNDING AREAS, PUBLIC OR PRIVATE, DESTROYED OR OTHERWISE DAMAGED BY THE CONTRACTOR'S OPERATIONS SHALL BE REPLACED OR REPAIRED TO THE SATISFACTION OF THE AUTHORITY HAVING JURISDICTION OF THE PROPERTY OR FACILITY BY THE CONTRACTOR AT THEIR OWN EXPENSE.
- CONTRACTOR SHALL PROVIDE AND MAINTAIN ALL NECESSARY BARRICADES AND TRAFFIC CONTROL DEVICES REQUIRED BY THE WASHTENAW COUNTY ROAD COMMISSION, CITY OF YPSILANTI, OR OTHER AGENCIES HAVING JURISDICTION.
- ALL ROADS, ROAD SHOULDERS, AND DRIVEWAYS DISTURBED BY THE CONTRACTOR'S OPERATIONS SHALL BE RESTORED AS CALLED FOR ON THE PLANS AND PAID FOR AT THE UNIT PRICES BUD.

## SAWCUTS

THE CONTRACTOR SHALL SAWCUT THE EXISTING CONCRETE AND/OR HMA PAVEMENT AND DRIVEWAYS TO THE LIMITS OF PROPOSED CONSTRUCTION, TO MAKE A NEAT AND SMOOTH CONNECTION TO THE EXISTING PAVEMENT OR DRIVEWAY AS REQUIRED AND DIRECTED. THIS WORK WILL NOT BE PAID FOR SEPARATELY, BUT WILL BE CONSIDERED INCLUDED IN THE CONTRACT UNIT PRICE BID FOR OTHER REMOVAL ITEMS.

## DUST CONTROL

THE CONTRACTOR SHALL BE RESPONSIBLE FOR DUST CONTROL ON THIS PROJECT. IT SHALL BE UNDERSTOOD THAT THIS IS A RESIDENTIAL NEIGHBORHOOD. KEEPING DUST TO A MINIMUM IS HIGH PRIORITY AND WILL BE EXPECTED TO BE MAINTAINED ON A REGULAR BASIS. DUST CONTROL WILL BE CONSIDERED INCIDENTAL TO THE PROJECT.

## PROTECTION OF EXISTING PAVEMENT

PAVEMENT DAMAGED BY THE CONTRACTOR IN AREAS WHERE PAVEMENT REMOVAL IS NOT SHOWN ON THE PLANS SHALL BE REMOVED AND REPLACED IN ACCORDANCE WITH THE CROSS SECTIONS PROVIDED IN THE PLANS. REMOVAL AND REPLACEMENT OF THESE AREAS SHALL BE AT THE CONTRACTOR'S EXPENSE.

## CLEANING PAVEMENT

BEFORE PLACING ANY HMA MIXTURE, THE SURFACE OF THE EXISTING PAVEMENT INCLUDING ALL CURBS, CRACKS, JOINTS, AND THE SURFACE OF THE NEW BASE AND LEVELING COURSES SHALL BE THOROUGHLY CLEANED OF ALL DEBRIS AND DIRT. THIS WORK WILL NOT BE PAID FOR SEPARATELY AND WILL BE CONSIDERED INCLUDED IN THE CONTRACT UNIT PRICE BID FOR OTHER HMA ITEMS.

## EXISTING CASTINGS

EXISTING UNDAMAGED CASTINGS DAMAGED BY THE CONTRACTOR SHALL BE REPLACED BY THE CONTRACTOR AT THEIR OWN EXPENSE IN KIND OR AS DETERMINED BY THE ENGINEER.

## PAVEMENT CORES

THE PAVEMENT CORES REPRESENT POINT INFORMATION. NO INFERENCE SHOULD BE MADE THAT SUBSURFACE OR PAVEMENT CONDITIONS ARE THE SAME AT OTHER LOCATIONS. THE PAVEMENT CORE LOGS CAN BE FOUND IN APPENDIX A.

## MISCELLANEOUS

THE CONTRACTOR SHALL BE RESPONSIBLE FOR ANY DAMAGE TO THE PROPERTY BEYOND THE PROJECT LIMIT, INCLUDING EXISTING FENCING, GUARDRAIL, LAWN, TREES AND SHRUBBERY. ALL AREAS DISTURBED BY THE CONTRACTOR AND/OR HIS/HER SUBCONTRACTOR(S) BEHIND THE NORMAL CONSTRUCTION LIMITS OF THIS PROJECT SHALL BE SODDED OR SEEDED AS SPECIFIED OR DIRECTED BY THE ENGINEER. NO ADDITIONAL PAYMENT OR COMPENSATION WILL BE ALLOWED FOR THIS ACTIVITY.

## UTILITIES

THE CONTRACTOR SHALL TAKE ALL NECESSARY PRECAUTIONS TO PROTECT UTILITIES FROM DAMAGE. THESE PRECAUTIONS ARE TO BE INCLUDED IN THE CONTRACT PAY ITEMS AND WILL NOT BE PAID FOR SEPARATELY.

FOR PROTECTION OF UNDERGROUND UTILITIES AND IN CONFORMANCE WITH PUBLIC ACT 174, THE CONTRACTOR SHALL DIAL 1-800-482-7171 A MINIMUM OF THREE FULL WORKING DAYS, EXCLUDING SATURDAYS, SUNDAYS AND HOLIDAYS, PRIOR TO BEGINNING EACH EXCAVATION IN AREAS WHERE PUBLIC UTILITIES HAVE NOT BEEN PREVIOUSLY LOCATED. MEMBERS WILL BE ROUTINELY NOTIFIED. THIS DOES NOT RELIEVE THE CONTRACTOR OF THE RESPONSIBILITY OF NOTIFYING UTILITY OWNERS WHO MAY NOT BE A PART OF THE "MISS DIG" ALERT SYSTEM. UTILITY LOCATIONS SHOWN ON THE PLANS ARE ONLY APPROXIMATE AND SHOULD BE LOCATED IN THE FIELD BEFORE EXCAVATING IN THE AREA.

THE FOLLOWING UTILITY COMPANIES HAVE FACILITIES WITHIN THE PROJECT LIMITS:

**INTERNET & TELEPHONE**  
AT&T  
550 S MAPLE ROAD  
ANN ARBOR, MI 48103  
ATTN: GARY CLINTON  
PH: 734-996-2135

54 N MILL STREET  
PONTIAC, MI 48342  
ATTN: C. ANIKA ESTES  
PH: 248-454-2998  
EMAIL: CE3239@ATT.COM

**CABLE TELEVISION**  
COMCAST  
25626 TELEGRAPH ROAD  
SOUTHFIELD, MI 48034  
ATTN: JEFF DOBIES  
PH: 734-359-1669

ATTN: CRAIG PUDAS  
PH: 248-809-2715  
EMAIL: CRAIG\_PUDAS@CABLE.COMCAST.COM

**GAS & ELECTRIC**  
DTE ENERGY  
982 BROADWAY STREET  
ANN ARBOR, MI 48105  
ATTN: JAMES BRENNAN JR  
PH: 1-800-338-0178  
ATTN: SARA KIPP  
PH: 313-407-5364  
PH: 248-318-7839

**WATER AND SANITARY**  
YPSILANTI COMM UTIL AUTH  
2777 STATE ROAD  
YPSILANTI, MI 48198  
ATTN: SEAN KNAPP  
PH: 734-484-4600  
EMAIL: MSTAKING@YCUA.ORG

TOTAL	UNIT	DESCRIPTION
1	LSUM	Maintenance of Traffic
1	LSUM	Mobilization, Max 10%

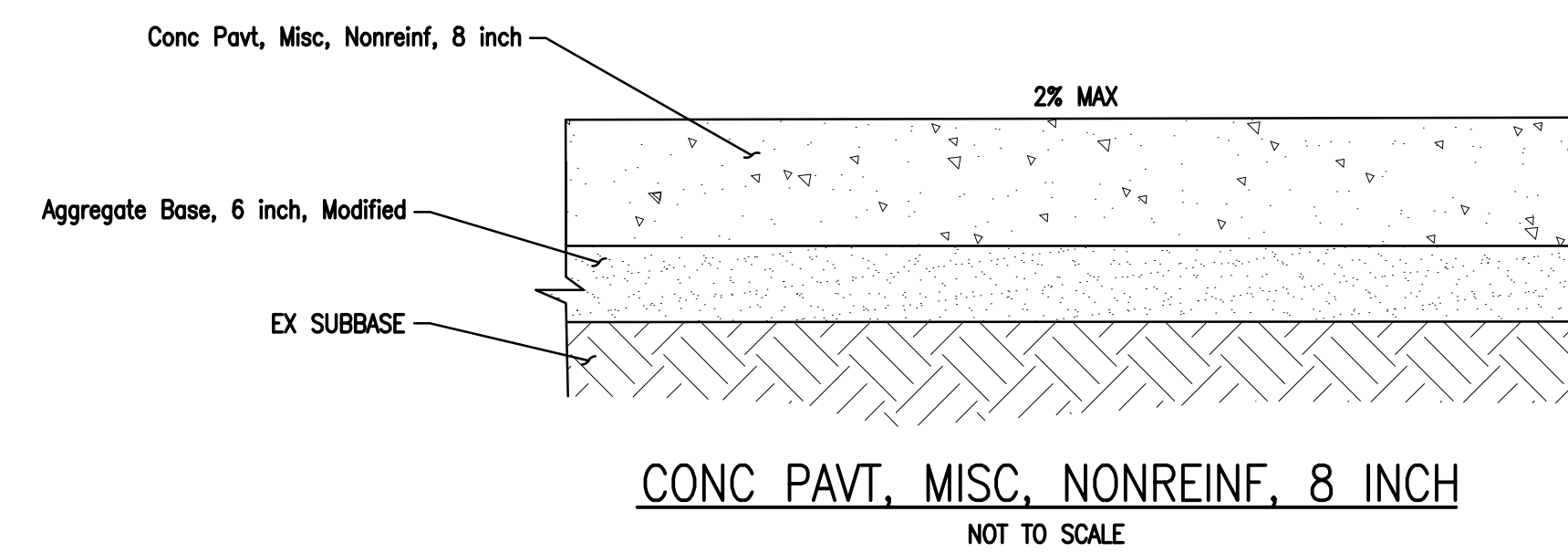
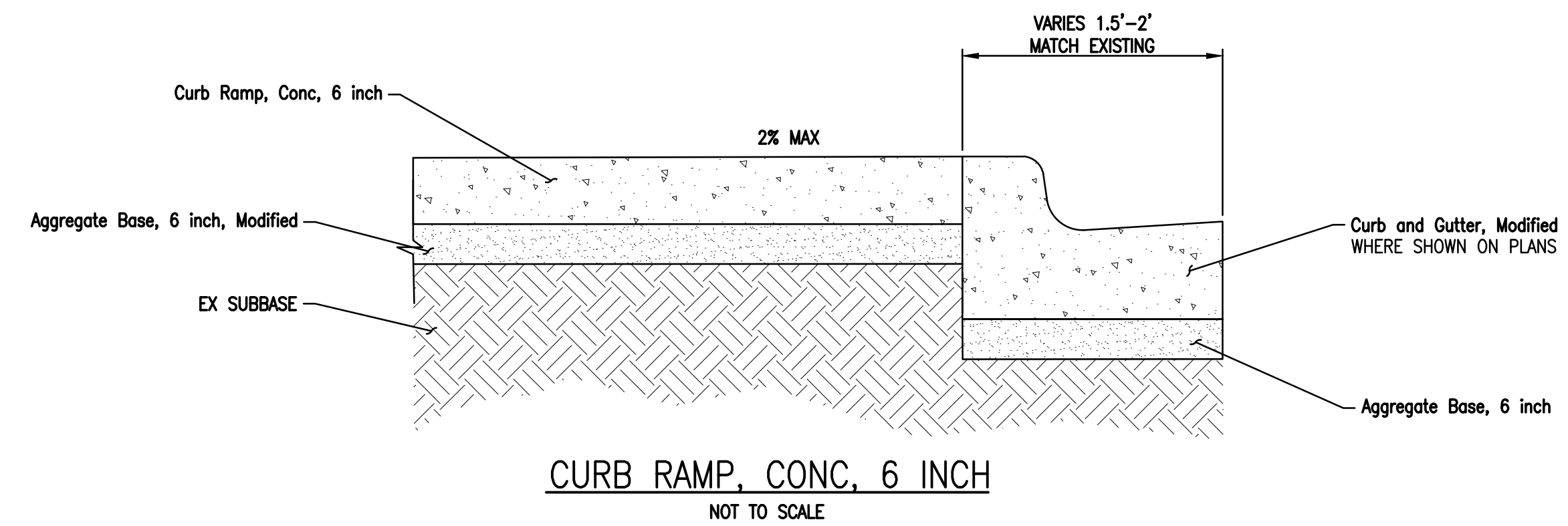
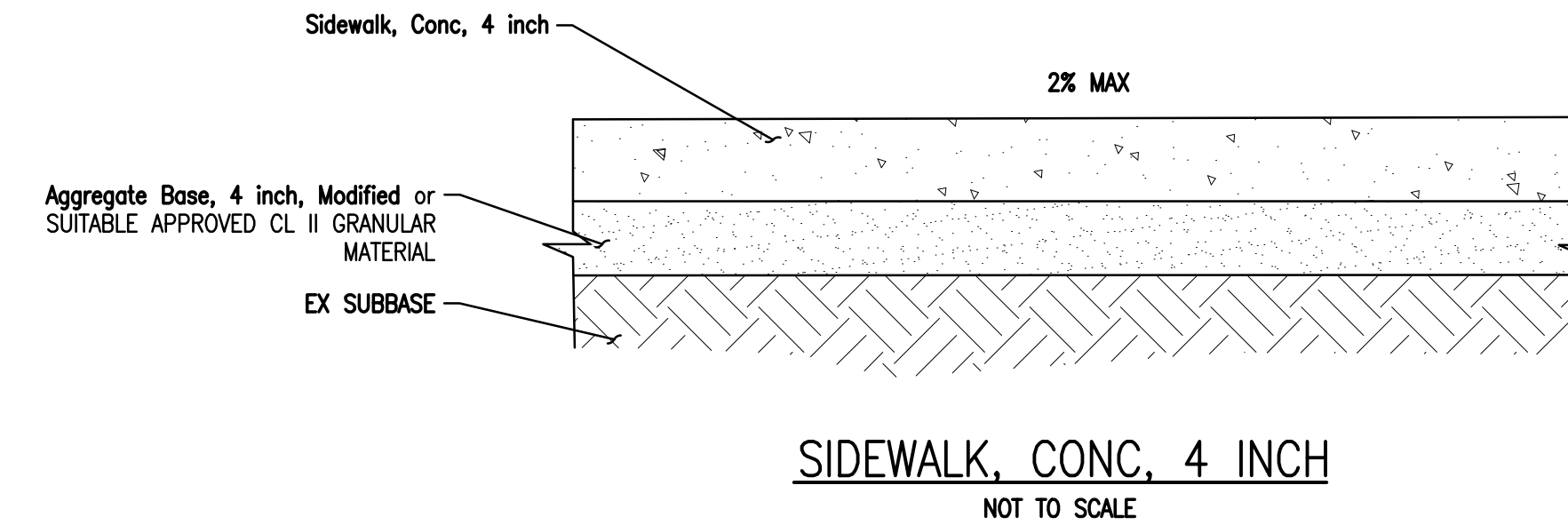
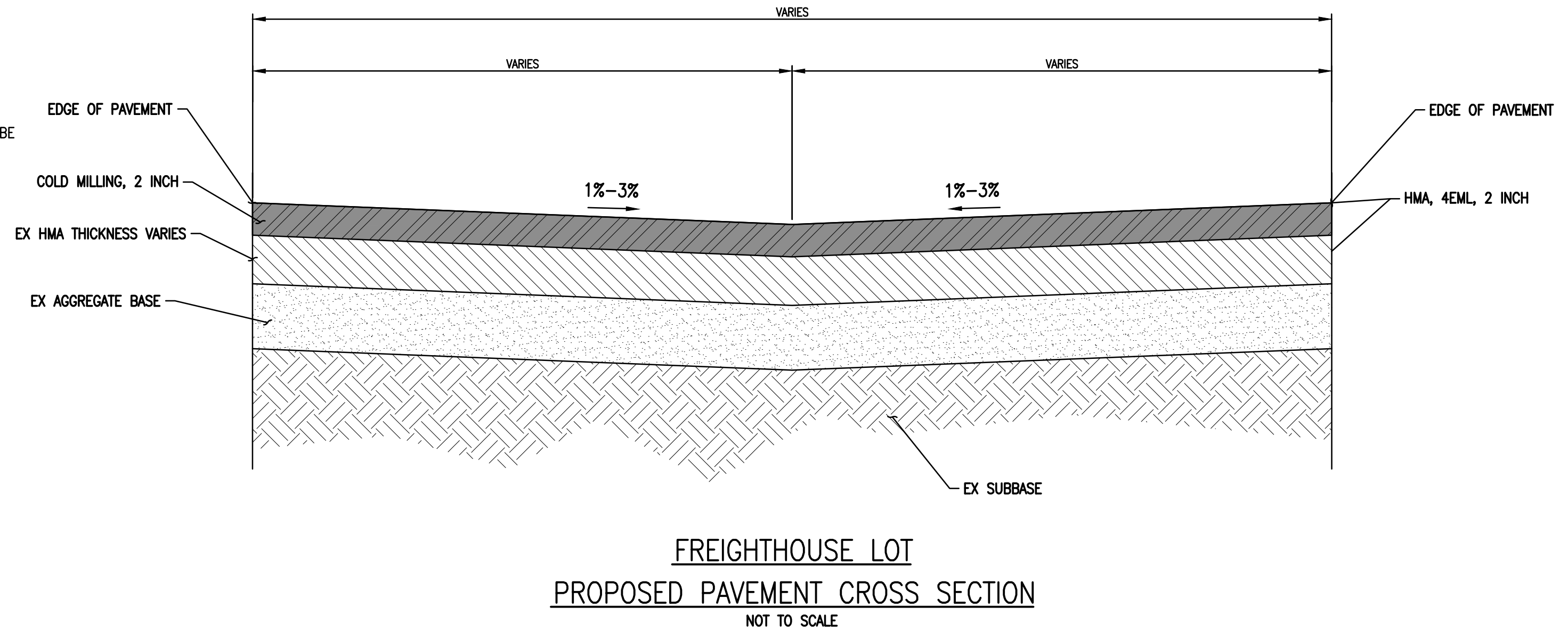
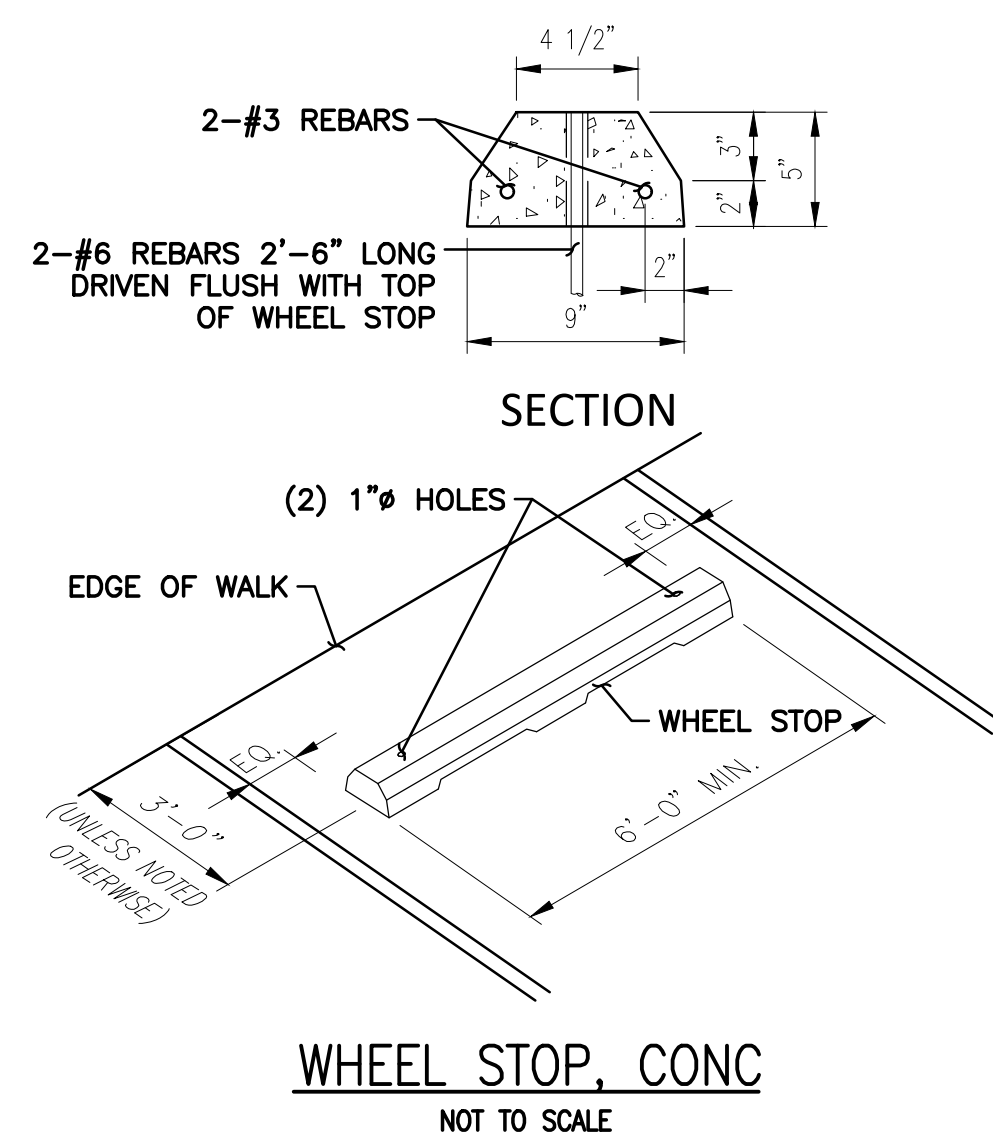

### NOTES:

- PLACE 1/4" CONTRACTION JOINTS AT 5' INTERVALS. PLACE 1/2" EXPANSION JOINTS AT 30' INTERVALS (MAX) USING JOINT FILLER WITH SEALANT.
- ADHERE TO ADA REQUIREMENTS FOR ALL SIDEWALK RAMP.
- CURB AND GUTTER, MODIFIED INCLUDES CURB RAMP OPENING.
- AGGREGATE BASE, 6 INCH PAID FOR SEPARATELY UNDER PROPOSED CURB.
- CONCRETE TO BE INSTALLED USING MDOT P1 CONCRETE (3500 PSI).

**WATER & SEWER UTILITY SYMBOLS**

- EXISTING**
- <sub>ST</sub> STORM MANHOLE
  - SQUARE CATCH BASIN
  - ⊕ ROUND CATCH BASIN
  - == CULVERT
  - ⊕ CULVERT W/O END SECTION
  - ) CULVERT W/END SECTION
  - <sub>S</sub> SANITARY MANHOLE
  - ⊙ CLEAN OUT
  - ⊗<sub>GW</sub> GATE VALVE & WELL
  - GATE VALVE & BOX
  - ⊕<sub>W</sub> WATER STOP BOX
  - ⊕ FIRE HYDRANT
  - ⊕<sub>MP</sub> METER PIT
  - ⊕ WATER METER
  - ⊕<sub>SH</sub> SPRINKLER HEAD
  - ⊕<sub>W</sub> IRRIGATION VALVE

- PROPOSED**
- STORM MANHOLE
  - INLET/CATCH BASIN
  - ⊕ CULVERT W/O END SECTION
  - ) CULVERT END SECTION
  - SANITARY MANHOLE
  - ⊗<sub>GW</sub> GATE VALVE & WELL
  - ⊗<sub>GW</sub> GATE VALVE & BOX
  - ⊗<sub>TSV</sub> TAPPING SLEEVE VALVE & WELL
  - ⊗<sub>TSV</sub> TAPPING SLEEVE VALVE & BOX
  - ⊕ FIRE HYDRANT

**REAL ESTATE SYMBOLS**

- ↔ CONTIGUOUS PROPERTY SYMBOL
- ⊗<sub>XXXX</sub> PARCEL NUMBER BOX
- ⊗<sub>XXX</sub> NO ROW IMPACTS

**MISCELLANEOUS UTILITY SYMBOLS**

- EXISTING**
- ↘ GUY WIRE
  - ⊕<sub>GP</sub> GUY POLE
  - ⊕<sub>U</sub> UTILITY POLE
  - ⊕<sub>T</sub> UTILITY POLE W/LIGHT
  - ⊕ LIGHT/DECOR LAMP POLE
  - ⊕ FLOOD LIGHT
  - ⊕ GAS VALVE
  - ⊕ GAS VENT
  - ⊕ GAS METER
  - ⊕ GAS RISER
  - ⊕ TRAFFIC SIGNAL
  - ⊕ PEDESTRIAN RISER
  - ⊕ TRANSFORMER PAD
  - ⊕ PRIVATE UTILITY MANHOLE
  - ⊕<sub>R</sub> RAILROAD CROSSING
  - ⊕ ELECTRIC METER
  - ⊕ PB PHONE BOOTH
  - ⊕ TS TRAFFIC SIGNAL CONTROLLER
  - ⊕ HAND HOLE
  - ⊕ ELECTRIC RISER
  - ⊕ TELEPHONE RISER
  - ⊕ CABLE TV RISER
  - ⊕<sub>W</sub> MONITORING WELL
  - ⊕ UNDERGROUND MARKER

**MISCELLANEOUS SYMBOLS**

- EXISTING**
- ⊕ RIPRAP
  - ↑ SIGN
  - FLOW DIRECTION
  - ⊕ STUMP
  - ⊕ WETLAND
  - ⊕ CONIFEROUS TREE } CL 1 1" TO 5"
  - ⊕ DECIDUOUS TREE } CL 2 6" TO 17"
  - ⊕ CONIFEROUS SHRUB } CL 3 18" TO 35"
  - ⊕ DECIDUOUS SHRUB } CL 4 36" AND UP
  - ⊕<sub>SB</sub> SOIL BORING
  - ⊕ SECTION CORNER
  - MONUMENT
  - IRON ROD/PIPE
  - ⊕ PK PK NAIL
  - <sub>BM</sub> BENCHMARK
  - ⊕<sub>TP</sub> TRAVERSE POINT
  - ⊕ MAIL/NEWSPAPER BOX
  - ⊕ FLAG POLE
  - POST

**HAZARDOUS OR FLAMMABLE MATERIAL** USED WITH UNDERGROUND GAS & ELECTRICAL LINES

**CAUTION - CRITICAL UNDERGROUND UTILITY** USED WITH TELEPHONE & FIBER OPTIC LINES

- PROPOSED**
- ⊕ RIPRAP
  - ↑, ↑, ↑, ↑, ↑, ↑ SIGN
  - FLOW DIRECTION
  - ⊕<sub>WM</sub> STRUCTURE NUMBER WM
  - ⊕<sub>SAN</sub> SAN
  - ⊕<sub>STM</sub> STM
  - ⊕ ADA SIDEWALK RAMP
  - ⊕ HMA
  - ⊕ CONCRETE

**UTILITY PATTERN**

- EXISTING**
- ELEC --- ELECTRICAL \*
  - 6" (COMPANY) GAS --- GAS/OIL
  - (COMPANY) CABLE/TEL --- CABLE/TELEPHONE \*
  - FIBER OPTIC --- FIBER OPTIC \*
  - 12" WM --- WATER
  - 12" SAN --- SANITARY
  - 12" STM --- STORM
- PROPOSED**
- 12" --- STORM/SANITARY/WATER
- PRIMARY UTILITY WILL HAVE A CONTINUOUS LIFESTYLE, WITH THE SECONDARY UTILITY MATCHING ITS RESPECTIVE EXISTING UTILITY LIFESTYLE
- \*O.H. = OVERHEAD , U.G. = UNDERGROUND

**ROW PATTERN**

- EXISTING**
- ROW --- ROW
  - SECTION --- SECTION
  - PROPERTY/PARCEL --- PROPERTY/PARCEL
- PROPOSED**
- ROW --- ROW

**TOPO PATTERN**

- EXISTING**
- HEDGE/TREE --- HEDGE/TREE
  - FENCE --- FENCE
  - GUARDRAIL --- GUARDRAIL
  - CENTERLINE OF DITCH --- CENTERLINE OF DITCH
  - RAILROAD --- RAILROAD
  - WETLAND/EDGE OF WATER --- WETLAND/EDGE OF WATER
- PROPOSED**
- GRADING LIMIT (SLOPE STAKE) --- GRADING LIMIT (SLOPE STAKE)
  - CENTERLINE OF DITCH --- CENTERLINE OF DITCH
  - GUARDRAIL --- GUARDRAIL
  - FENCE --- FENCE

**REMOVAL LEGEND**

- ▨ SIDEWALK REMOVAL
- ▨ HMA SURFACE REMOVAL
- ▨ PAVEMENT REMOVAL
- ▨ COLD MILLING HMA SURFACE
- ▨ HMA BASE CRUSHING AND SHAPING
- ▨ EXCAVATION, EARTH, MODIFIED
- ⊗ CURB AND GUTTER, REM
- ⊗ TREE, REM
- S-XXXXXX SALVAGE
- B-XXXXXX BULKHEAD
- A-XXXXXX ABANDON
- R-XXXXXX REMOVE
- ADJ-XXXXXX ADJUST
- REL-XXXXXX RELOCATE
- REC-XXXXXX RECONSTRUCT
- R B/O-XXXXXX REMOVE BY OTHERS
- ADJ B/O-XXXXXX ADJUST BY OTHERS
- REL B/O-XXXXXX RELOCATE BY OTHERS

**IF NECESSARY FOR CLARITY**

- ⊕ SALVAGE
- ⊕ BULKHEAD
- ⊕ ABANDON
- ⊕ CLEARING
- ⊕ REMOVE
- REL RELOCATE
- REC RECONSTRUCT
- REL B/O RELOCATE BY OTHERS
- ADJ B/O ADJUST BY OTHERS

**SPECIAL LEGEND**



REVISION	DESCRIPTION	DATE
04/07/2026		

ISSUED FOR: CHANGE ORDER NO 1  
 8/29/2025 BID SUBMITTAL  
 09/04/2025 ADDENDUM NO 1  
 04/07/2026 CHANGE ORDER NO 1

PROJECT NUMBER: PM 094-25-0070  
 RU  
**CITY OF YPSILANTI**  
**FREIGHTHOUSE LOT REHABILITATION**  
 YPSILANTI, MI  
**LEGEND**

COPYRIGHT 2026 OHM. ALL DRAWINGS AND WRITTEN MATERIALS APPEARING HEREIN CONSTITUTE THE ORIGINAL AND UNPUBLISHED WORK OF OHM AND THE SAME MAY NOT BE DUPLICATED, DISTRIBUTED, OR DISCLOSED WITHOUT PRIOR WRITTEN CONSENT OF OHM.

# FREIGHTHOUSE LOT

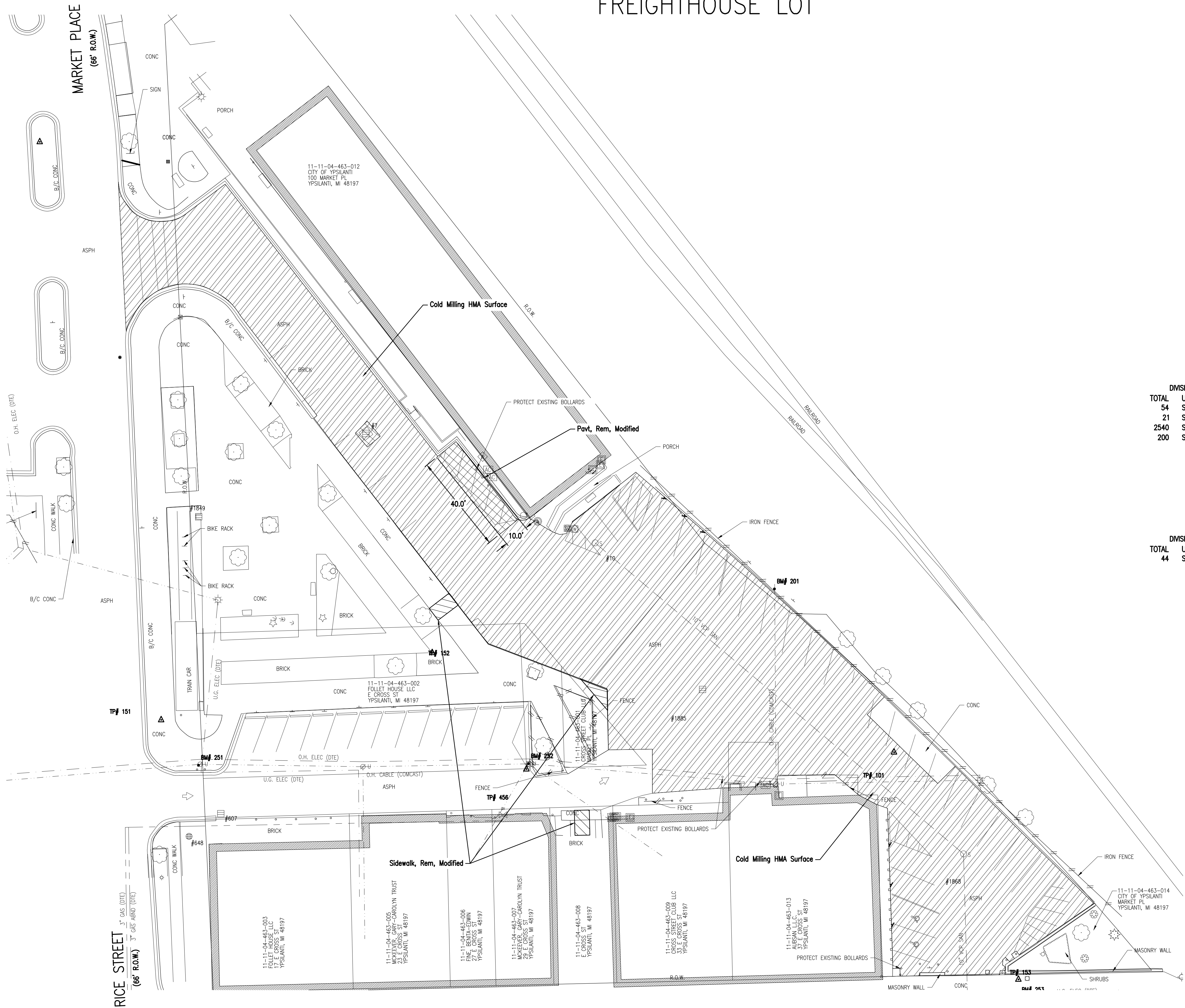
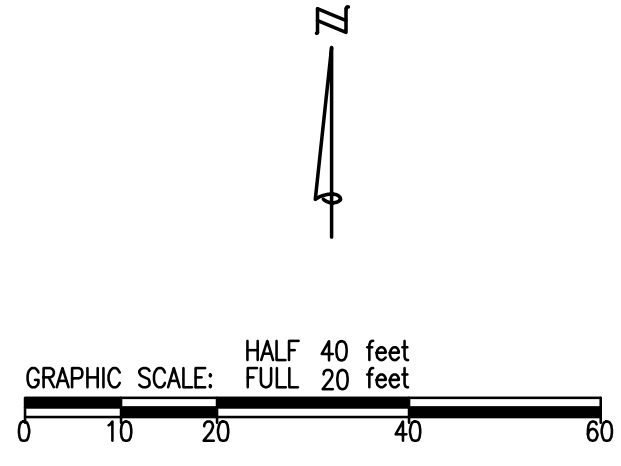

**DIVISION B - QUANTITIES THIS SHEET**

TOTAL	UNIT	DESCRIPTION
54	Syd	Pavt, Rem, Modified
21	Syd	Sidewalk, Rem, Modified
2540	Syd	Cold Milling HMA Surface
200	Syd	Full Depth Patch, Rem, Modified

**DIVISION C - QUANTITIES THIS SHEET**

TOTAL	UNIT	DESCRIPTION
44	Syd	Cold Milling HMA Surface

REVISION	DESCRIPTION	DATE
04/07/2026	ISSUED FOR CHANGE ORDER NO 1	04/07/2026
02/20/2025	BID SUBMITTAL	
09/04/2025	ADDENDUM NO 1	
04/07/2026	CHANGE ORDER NO 1	

PROJECT NUMBER: 0094-25-0070  
 CITY OF YPSILANTI  
 FREIGHTHOUSE LOT REHABILITATION  
 YPSILANTI, MI  
 REMOVAL PLAN



Know what's below.  
Call before you dig.

# FREIGHTHOUSE LOT

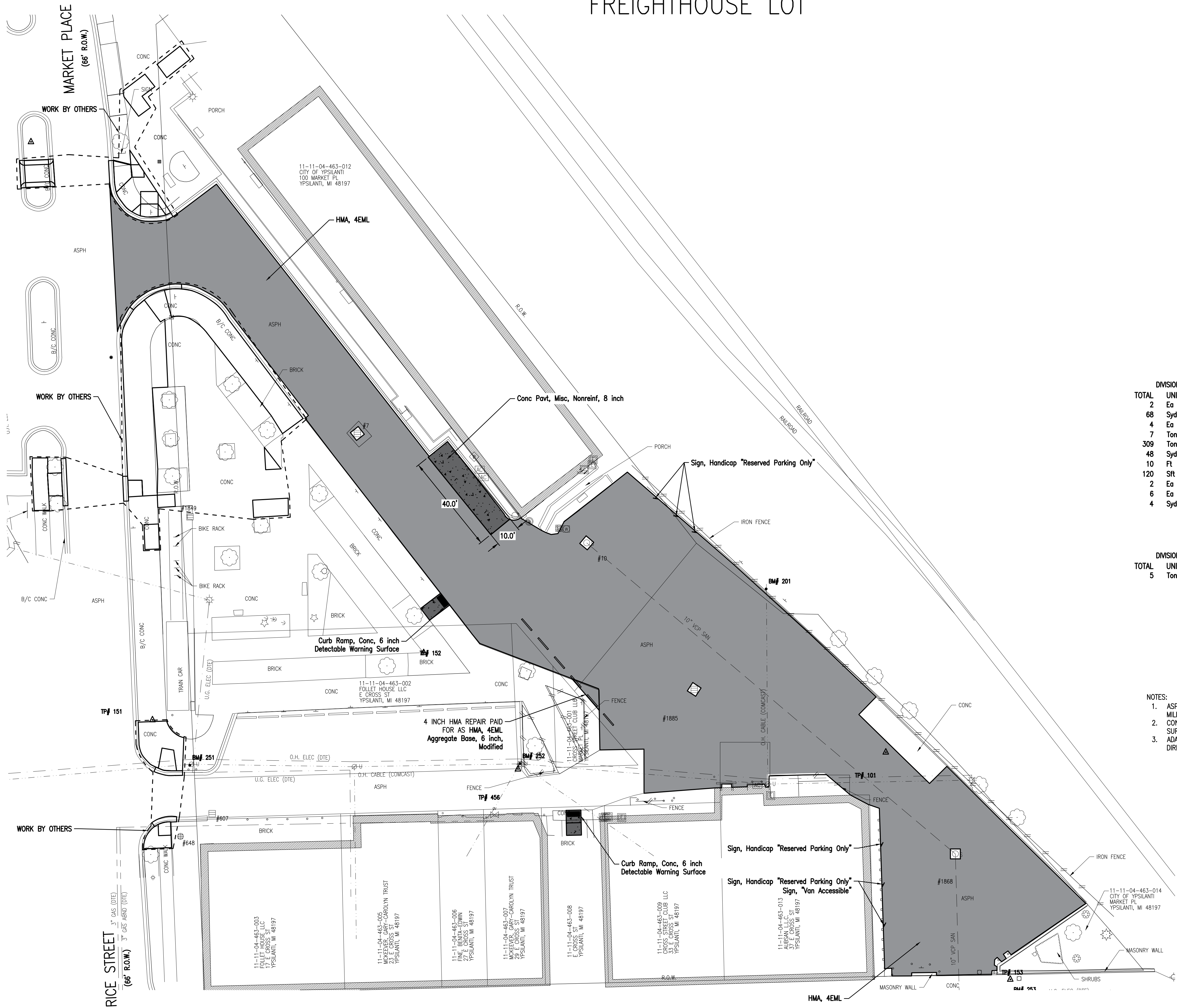
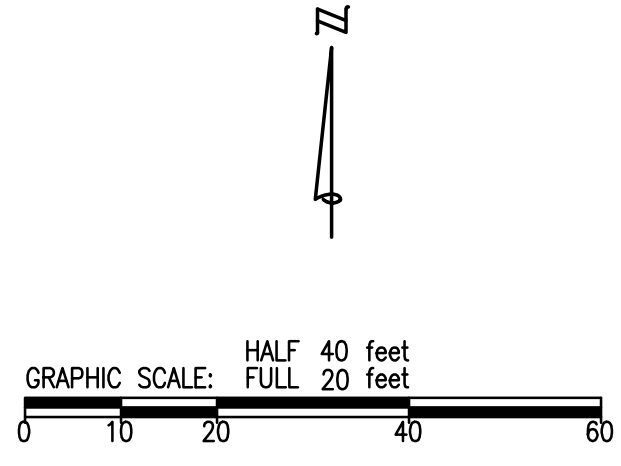

**DIVISION B - QUANTITIES THIS SHEET**

TOTAL	UNIT	DESCRIPTION
2	Ea	Erosion Control, Inlet Protection, Fabric Drop
68	Syd	Aggregate Base, 6 inch, Modified
4	Ea	Utility Structure Cover, Adj, Case 1
7	Ton	Hand Patching
309	Ton	HMA, 4EML
48	Syd	Conc Pavt, Nonreinf, 8 inch
10	Ft	Detectable Warning Surface
120	Sft	Curb Ramp, Conc, 6 inch
2	Ea	Sign, "Van Accessible"
6	Ea	Sign, Handicap "Reserved Parking Only"
4	Syd	Surface Restoration, Modified

**DIVISION C - QUANTITIES THIS SHEET**

TOTAL	UNIT	DESCRIPTION
5	Ton	HMA, 4EML

- NOTES:**
1. ASPHALT SHALL BE POURED WITHIN 2 DAYS (48 HOURS) OF MILLING OPERATIONS.
  2. CONTRACTOR SHALL PROVIDE POSITIVE DRAINAGE ON ASPHALT SURFACE. INLETS SHALL BE THE LOW POINT IN THE PAVED AREA.
  3. ADA SPACES SHALL HAVE A MAXIMUM SLOPE OF 2% IN ALL DIRECTIONS.

ISSUED FOR:	CHANGE ORDER NO. 1	DATE
8/29/2025 BID SUBMITTAL		04/07/2026
09/04/2025 ADDENDUM NO. 1		
04/07/2026 CHANGE ORDER NO. 1		

PROJECT NUMBER: 009425-0070  
 CITY OF YPSILANTI  
 BALLARD LOT REHABILITATION  
 YPSILANTI, MI  
 CONSTRUCTION PLAN



Know what's below.  
Call before you dig.

DRAWING PATH: P:\0000\_010000\094250070\_Ballard\_Lot\_Rehabilitation\Drawings\CP\Plans\_Constr\25071\CON.dwg April 14, 2025 - 2:19 PM

COPYRIGHT 2026 OHM. ALL DRAWINGS AND WRITTEN MATERIALS APPEARING HEREIN CONSTITUTE THE ORIGINAL AND UNPUBLISHED WORK OF OHM AND THE SAME MAY NOT BE DUPLICATED, DISTRIBUTED, OR DISCLOSED WITHOUT PRIOR WRITTEN CONSENT OF OHM

# FREIGHTHOUSE LOT

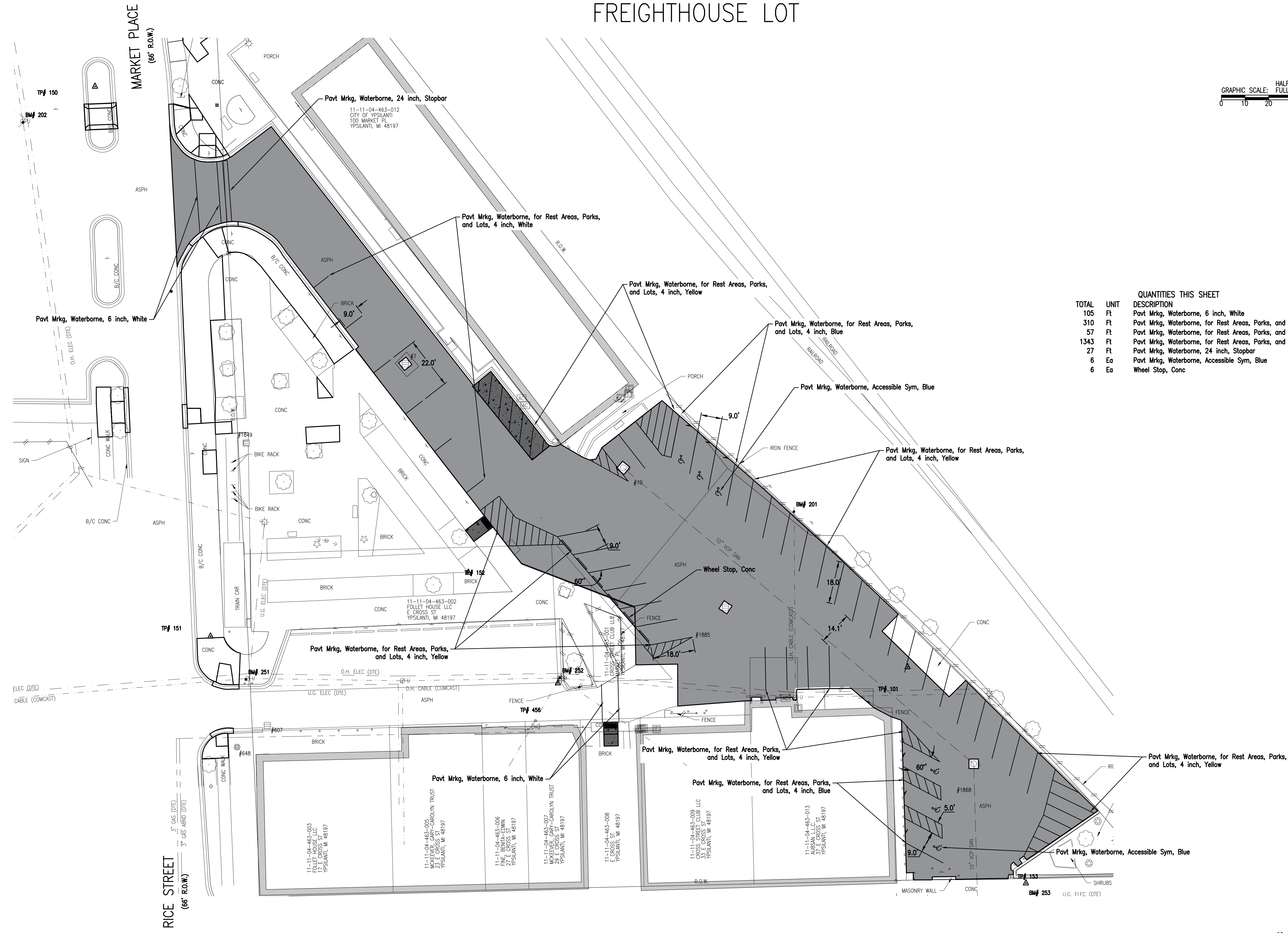
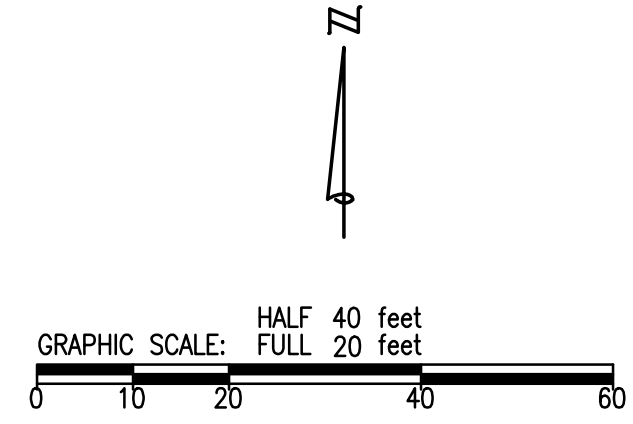

QUANTITIES THIS SHEET	
TOTAL	DESCRIPTION
105	Ft Pavt Mrkg, Waterborne, 6 inch, White
310	Ft Pavt Mrkg, Waterborne, for Rest Areas, Parks, and Lots, 4 inch, Blue
57	Ft Pavt Mrkg, Waterborne, for Rest Areas, Parks, and Lots, 4 inch, Yellow
1343	Ft Pavt Mrkg, Waterborne, for Rest Areas, Parks, and Lots, 4 inch, White
27	Ft Pavt Mrkg, Waterborne, 24 inch, Stopbar
6	Ea Pavt Mrkg, Waterborne, Accessible Sym, Blue
6	Ea Wheel Stop, Conc

REVISION	DESCRIPTION	DATE
04/07/2026	ISSUED FOR CHANGE ORDER NO 1	
02/20/2025	BID SUBMITTAL	
09/04/2025	ADDENDUM NO 1	
04/07/2026	CHANGE ORDER NO 1	

PROJECT NUMBER: 0094262070  
 CITY OF YPSILANTI  
 FREIGHTHOUSE LOT REHABILITATION  
 YPSILANTI, MI  
 PAVEMENT MARKINGS PLAN



Know what's below.  
Call before you dig.

DRAWING PATH: P:\000\_0100\094262070\_Behnd\_Lot\_Rehabilitate\Drawings\CP\PM\026071\PM.dwg April 14, 2026 - 2:19 PM

COPYRIGHT 2026 OHM. ALL DRAWINGS AND WRITTEN MATERIALS APPEARING HEREIN CONSTITUTE THE ORIGINAL AND UNPUBLISHED WORK OF OHM AND THE SAME MAY NOT BE DUPLICATED, DISTRIBUTED, OR DISCLOSED WITHOUT PRIOR WRITTEN CONSENT OF OHM

# FREIGHTHOUSE LOT

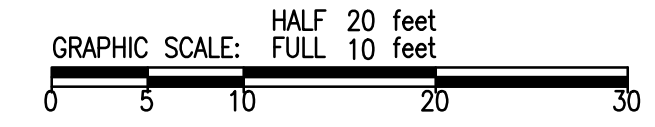
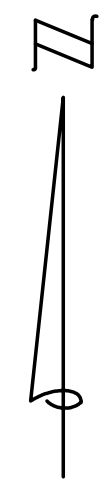
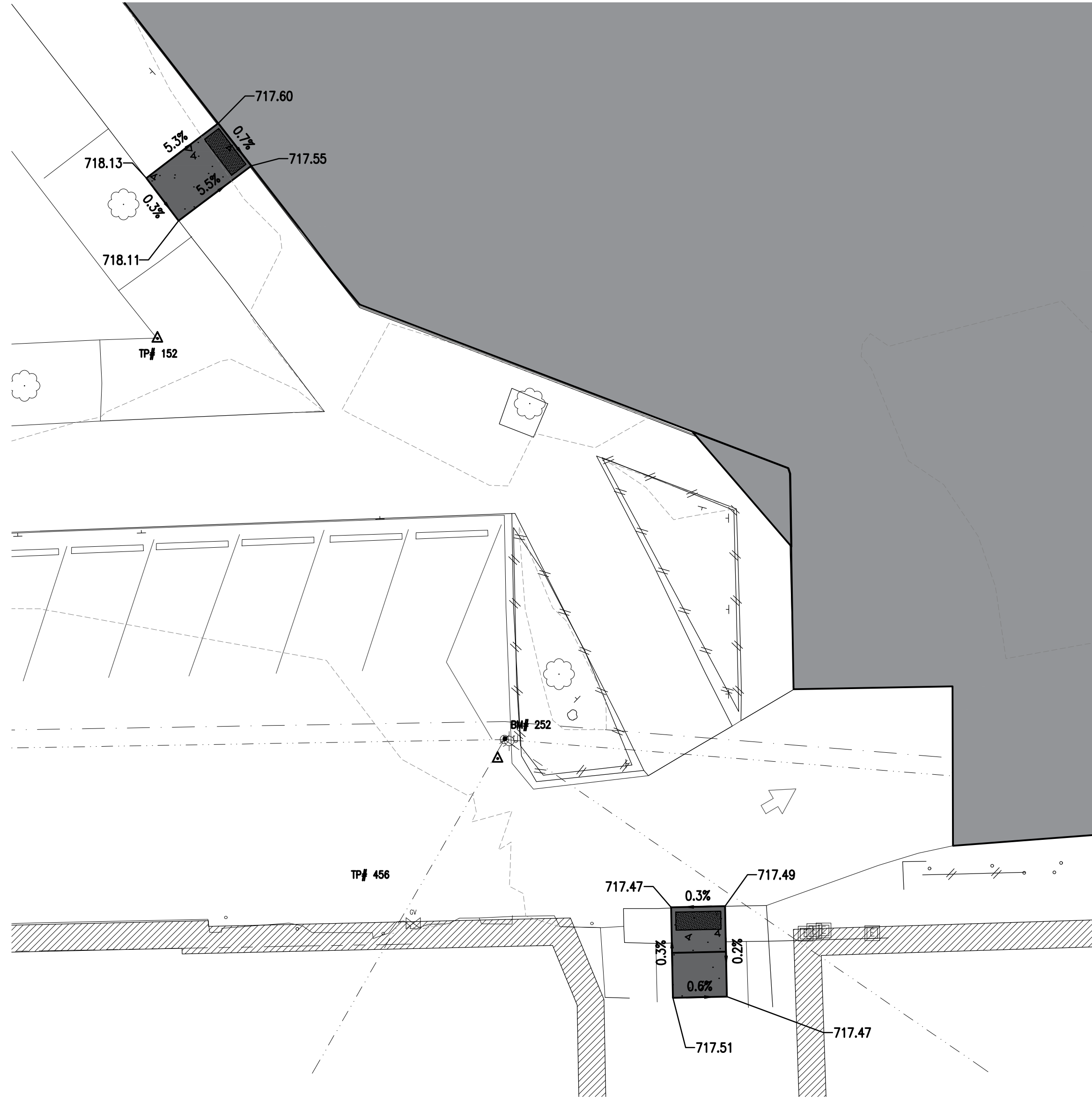

### LEGEND

- TC TOP OF CURB
- EP EDGE OF PAVEMENT
- ES EDGE OF SHOULDER
- G GUTTER
- EW EDGE OF WALK
- T/CAST TOP OF CAST
- HP/LP HIGH POINT/LOW POINT

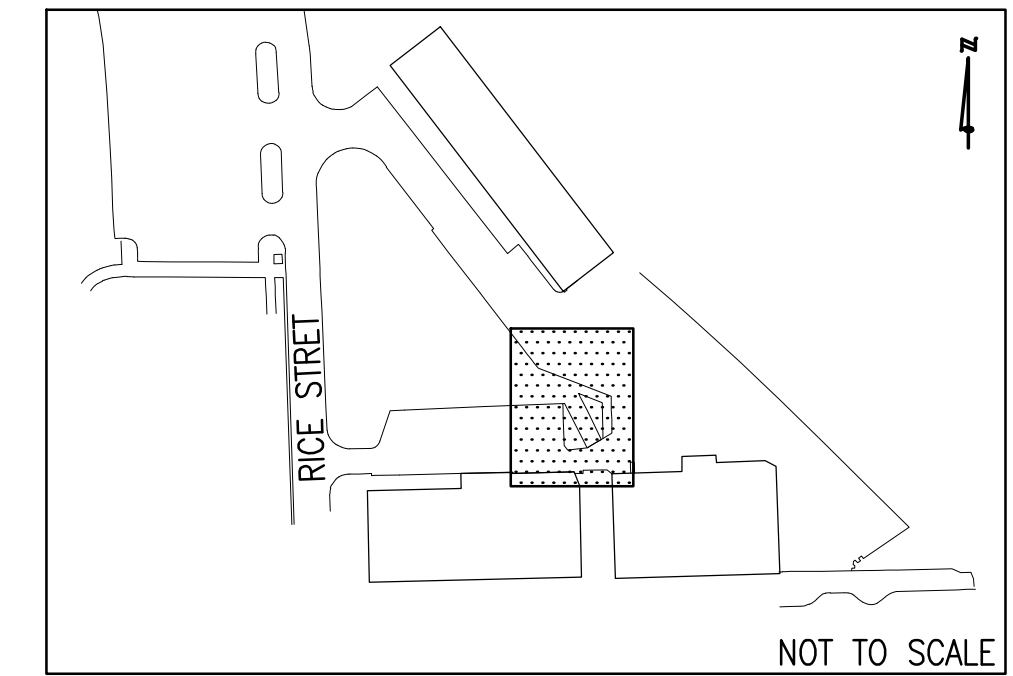

Know what's below.  
Call before you dig.



ISSUED FOR: CHANGE ORDER NO 1	DATE
8/28/2025 BID SUBMITTAL	04/07/2026
09/04/2025 ADDENDUM NO 1	
04/07/2026 CHANGE ORDER NO 1	

PROJECT NUMBER: 0894-25-0070  
 CITY OF YPSILANTI  
 FREIGHTHOUSE LOT REHABILITATION  
 YPSILANTI, MI  
 ADA GRADING PLAN

**CONTRACT SUMMARY**  
**City of Ypsilanti Municipal Lots Rehabilitation**  
**City of Ypsilanti, Washtenaw County, State of Michigan**  
**OHM Job Number: 0094-25-0070**

Item	Description	Quantity	Unit	Unit Price	Amount
<b>Division A: Ballard Lot Reconstruction</b>					
1	Mobilization, Max 10%	1	LSUM	\$ 1,500.00	\$ 1,500.00
2	Maintenance of Traffic	1	LSUM	\$ 1,500.00	\$ 1,500.00
3	Erosion Control, Inlet Protection, Fabric Drop	2	Ea	\$ 200.00	\$ 400.00
4	Utility Structure Cover, Adj, Case 1	2	Ea	\$ 1,000.00	\$ 2,000.00
5	Hand Patching	10	Ton	\$ 250.00	\$ 2,500.00
6	HMA, 4EML	120	Ton	\$ 170.00	\$ 20,400.00
7	Sign, Handicap "Reserved Parking Only"	2	Ea	\$ 750.00	\$ 1,500.00
8	Sign, "Van Accessible"	2	Ea	\$ 250.00	\$ 500.00
9	Pavt Mrkg, Ballard Lot	1	LSUM	\$ 1,000.00	\$ 1,000.00
10	Pavt, Rem, Modified	1,400	Syd	\$ 13.40	\$ 18,760.00
11	Aggregate Base, 6 inch, Modified	1,400	Syd	\$ 15.00	\$ 21,000.00
12	Dr Structure, Tap, 4 inch	2	Ea	\$ 500.00	\$ 1,000.00
13	Underdrain, Subgrade, 4 inch	300	Ft	\$ 14.00	\$ 4,200.00
14	HMA, 3C	200	Ton	\$ 170.00	\$ 34,000.00
15	SESC Permit Allowance	1	Dlr	\$ 500.00	\$ 500.00
<b>Total 'Division A' Amount :</b>					<b>\$ 110,760.00</b>
<b>Division B: Freighthouse Lot Rehabilitation</b>					
16	Mobilization, Max 10%	1	LSUM	\$ 2,500.00	\$ 2,500.00
17	Maintenance of Traffic	1	LSUM	\$ 1,000.00	\$ 1,000.00
18	Pavt, Rem, Modified	60	Syd	\$ 15.00	\$ 900.00
19	Sidewalk, Rem, Modified	15	Syd	\$ 35.00	\$ 525.00
20	Erosion Control, Inlet Protection, Fabric Drop	2	Ea	\$ 200.00	\$ 400.00
21	Full Depth Patch, Rem, Modified	200	Syd	\$ 12.00	\$ 2,400.00
22	Aggregate Base, 6 inch, Modified	100	Syd	\$ 30.00	\$ 3,000.00
23	Utility Structure Cover, Adj, Case 1	3	Ea	\$ 1,000.00	\$ 3,000.00
24	Sanitary Sewer Manhole Cover, Adj, Case 1	1	Ea	\$ 1,000.00	\$ 1,000.00
25	Conc Pavt, Nonreinf, 8 inch	45	Syd	\$ 90.00	\$ 4,050.00
26	Cold Milling HMA Surface	2,555	Syd	\$ 4.65	\$ 11,880.75
27	Hand Patching	10	Ton	\$ 250.00	\$ 2,500.00
28	HMA, 4EML	344	Ton	\$ 168.00	\$ 57,792.00
29	Detectable Warning Surface	10	Ft	\$ 100.00	\$ 1,000.00
30	Curb Ramp, Conc, 6 inch	150	Sft	\$ 12.50	\$ 1,875.00
31	Pavt Mrkg, Freighthouse Lot	1	LSUM	\$ 1,500.00	\$ 1,500.00
32	Surface Restoration, Modified	5	Syd	\$ 200.00	\$ 1,000.00
33	Wheel Stop, Conc	6	Ea	\$ 150.00	\$ 900.00
34	Sign, Handicap "Reserved Parking Only"	6	Ea	\$ 750.00	\$ 4,500.00
35	Sign, "Van Accessible"	2	Ea	\$ 250.00	\$ 500.00
<b>Total 'Division B' Amount:</b>					<b>\$ 102,222.75</b>
<b>Division C: Aubree's - Private Property</b>					
36	Cold Milling HMA Surface	45	Syd	\$ 4.65	\$ 209.25
37	HMA, 4EML	6	Ton	\$ 168.00	\$ 1,008.00
<b>Total 'Division C' Amount:</b>					<b>\$ 1,217.25</b>
<b>Total Amount (Items 1-37) :</b>					<b>\$ 214,200.00</b>

**Tabulation for Bids Received on 9/11/25**  
**City of Ypsilanti Municipal Lots Rehabilitation**  
**City of Ypsilanti, Washtenaw County, State of Michigan**  
**OHM Job Number: 0094-25-0070**

Sommerset Paving Companies., LLC  
11734 Whitmore Lake Road  
Whitmore Lake, MI 48189  
  
734-929-0641

Best Asphalt, Inc.  
6334 N Beverly Plaza  
Romulus, MI 48174  
  
734-729-9440

S & J Asphalt Paving Company  
39571 Michigan Avenue  
Canton, MI 48188  
  
734-721-4442

Anglin Civil, LLC  
13000 Newburgh Road  
Livonia, MI 48150  
  
734-464-2600

Item	Description	Quantity	Unit	Unit Price	Amount	Unit Price	Amount	Unit Price	Amount	Unit Price	Amount
<b>Division A: Ballard Lot Rehabilitation (Construction 2025)</b>											
1	Mobilization, Max 10%	1	LSUM	\$1,500.00	\$1,500.00	\$2,500.00	\$2,500.00	\$2,500.00	\$2,500.00	\$7,218.75	\$7,218.75
2	Maintenance of Traffic	1	LSUM	\$1,000.00	\$1,000.00	\$1,000.00	\$1,000.00	\$750.00	\$750.00	\$3,000.00	\$3,000.00
3	Erosion Control, Inlet Protection, Fabric Drop	2	Ea	\$200.00	\$400.00	\$150.00	\$300.00	\$250.00	\$500.00	\$181.44	\$362.88
4	Full Depth Patch, Rem, Modified	100	Syd	\$16.00	\$1,600.00	\$35.00	\$3,500.00	\$10.00	\$1,000.00	\$223.12	\$22,312.00
5	Utility Structure Cover, Adj, Case 1	2	Ea	\$1,000.00	\$2,000.00	\$600.00	\$1,200.00	\$500.00	\$1,000.00	\$1,285.39	\$2,570.78
6	Cold Milling HMA Surface	1,400	Syd	\$4.00	\$5,600.00	\$8.00	\$11,200.00	\$10.00	\$14,000.00	\$5.74	\$8,036.00
7	Hand Patching	10	Ton	\$250.00	\$2,500.00	\$400.00	\$4,000.00	\$300.00	\$3,000.00	\$692.32	\$6,923.20
8	HMA, 4EML	120	Ton	\$205.00	\$24,600.00	\$170.00	\$20,400.00	\$200.00	\$24,000.00	\$221.83	\$26,619.60
9	Sign, Handicap "Reserved Parking Only"	2	Ea	\$750.00	\$1,500.00	\$400.00	\$800.00	\$325.00	\$650.00	\$306.00	\$612.00
10	Sign, "Van Accessible"	2	Ea	\$250.00	\$500.00	\$400.00	\$800.00	\$50.00	\$100.00	\$96.00	\$192.00
11	Pavt Mrkg, Ballard Lot	1	LSUM	\$1,000.00	\$1,000.00	\$1,000.00	\$1,000.00	\$1,200.00	\$1,200.00	\$738.00	\$738.00
<b>Total 'Division A' Amount (Items 1-11):</b>					<b>\$42,200.00</b>		<b>\$46,700.00</b>		<b>\$48,700.00</b>		<b>\$78,585.21</b>
<b>Division B: Freighthouse Lot Rehabilitation (Construction 2026)</b>											
12	Mobilization, Max 10%	1	LSUM	\$2,500.00	\$2,500.00	\$6,000.00	\$6,000.00	\$3,500.00	\$3,500.00	\$22,916.25	\$22,916.25
13	Maintenance of Traffic	1	LSUM	\$1,000.00	\$1,000.00	\$2,500.00	\$2,500.00	\$1,000.00	\$1,000.00	\$3,150.00	\$3,150.00
14	Pavt, Rem, Modified	45	Syd	\$20.00	\$900.00	\$25.00	\$1,125.00	\$25.00	\$1,125.00	\$175.42	\$7,893.90
15	Curb and Gutter, Rem	150	Ft	\$15.00	\$2,250.00	\$10.00	\$1,500.00	\$17.00	\$2,550.00	\$10.90	\$1,635.00
16	Sidewalk, Rem, Modified	450	Syd	\$14.00	\$6,300.00	\$14.00	\$6,300.00	\$17.00	\$7,650.00	\$24.70	\$11,115.00
17	Erosion Control, Inlet Protection, Fabric Drop	2	Ea	\$200.00	\$400.00	\$150.00	\$300.00	\$250.00	\$500.00	\$181.44	\$362.88
18	Full Depth Patch, Rem, Modified	200	Syd	\$12.00	\$2,400.00	\$25.00	\$5,000.00	\$15.00	\$3,000.00	\$210.95	\$42,190.00
19	Aggregate Base, 6 inch, Modified	150	Syd	\$26.00	\$3,900.00	\$22.00	\$3,300.00	\$20.00	\$3,000.00	\$25.33	\$3,799.50
20	Utility Structure Cover, Adj, Case 1	3	Ea	\$1,000.00	\$3,000.00	\$600.00	\$1,800.00	\$500.00	\$1,500.00	\$1,552.16	\$4,656.48
21	Sanitary Sewer Manhole Cover, Adj, Case 1	1	Ea	\$1,000.00	\$1,000.00	\$1,800.00	\$1,800.00	\$750.00	\$750.00	\$1,553.18	\$1,553.18
22	Conc Pavt, Nonreinf, 8 inch	45	Syd	\$80.00	\$3,600.00	\$77.00	\$3,465.00	\$130.00	\$5,850.00	\$93.52	\$4,208.40
23	Cold Milling HMA Surface	2,900	Syd	\$4.50	\$13,050.00	\$6.00	\$17,400.00	\$7.50	\$21,750.00	\$4.30	\$12,470.00
24	Hand Patching	10	Ton	\$250.00	\$2,500.00	\$400.00	\$4,000.00	\$300.00	\$3,000.00	\$443.88	\$4,438.80
25	HMA, 4EML	400	Ton	\$165.00	\$66,000.00	\$145.00	\$58,000.00	\$155.00	\$62,000.00	\$177.64	\$71,056.00
26	Curb and Gutter, Modified	150	Ft	\$38.00	\$5,700.00	\$38.50	\$5,775.00	\$45.00	\$6,750.00	\$49.71	\$7,456.50
27	Detectable Warning Surface	55	Ft	\$90.00	\$4,950.00	\$88.00	\$4,840.00	\$70.00	\$3,850.00	\$84.00	\$4,620.00
28	Sidewalk, Conc, 4 inch	3,100	Sft	\$6.50	\$20,150.00	\$6.60	\$20,460.00	\$8.00	\$24,800.00	\$8.06	\$24,986.00
29	Curb Ramp, Conc, 6 inch	500	Sft	\$10.50	\$5,250.00	\$11.00	\$5,500.00	\$15.00	\$7,500.00	\$12.90	\$6,450.00
30	Sign, Remove and Reset	5	Ea	\$200.00	\$1,000.00	\$175.00	\$875.00	\$300.00	\$1,500.00	\$432.18	\$2,160.90
31	Pavt Mrkg, Freighthouse Lot	1	LSUM	\$1,500.00	\$1,500.00	\$1,500.00	\$1,500.00	\$3,000.00	\$3,000.00	\$3,150.00	\$3,150.00
32	Surface Restoration, Modified	30	Syd	\$50.00	\$1,500.00	\$47.00	\$1,410.00	\$60.00	\$1,800.00	\$547.46	\$16,423.80
32	Wheel Stop, Conc	6	Ea	\$150.00	\$900.00	\$130.00	\$780.00	\$200.00	\$1,200.00	\$131.25	\$787.50
<b>Total 'Division B' Amount (Items 12-33):</b>					<b>\$149,750.00</b>		<b>\$153,630.00</b>		<b>\$167,575.00</b>		<b>\$257,480.09</b>
<b>Total 'Division A' + 'Division B' Amount:</b>					<b>\$191,950.00</b>		<b>\$200,330.00</b>		<b>\$216,275.00</b>		<b>\$336,065.30</b>

# Change Order

## No. 01

Date of Issuance: April 14, 2026 Effective Date: \_\_\_\_\_

Project: <b>Municipal Parking Lots Rehabilitation</b>	Owner: <b>City of Ypsilanti</b>	Owner's Contract No.:
Contract: <b>Ballard Lot Reconstruction &amp; Freighthouse Lot Rehabilitation</b>		Date of Contract: <b>9/11/2025 (approx.)</b>
Contractor: <b>Sommerset Paving Companies, LLC</b>		Engineer's Project No.: <b>0094-25-0070</b>

**The Contract Documents are modified as follows upon execution of this Change Order:**

Description:

Scope of work for Division A changed from a rehabilitation (mill & overlay) to a pavement reconstruction. This includes a new pavement section with 6-inch aggregate base with a 4-inch HMA section. Division A also added underdrain to the project scope. Division A prices only apply to Division A pay items. Division B remains a mill & overlay, but some of the sidewalk repairs and sidewalk ramps have been removed from the scope of work. Division B pavement marking plan has been revised and there is now a Division C for private work that reduced some Division B quantities. Division B prices only apply to Division B pay items. Division C prices only apply to Division C pay items. The new prices and construction plans are superseding the original contract documents.

**Attachments (list documents supporting change):**

Construction Plans revised April 1, 2026 per Change Order 01; Original Bid Tabulation; Contract Summary reflecting revised unit prices & pay items; revised April 1, 2026 Special Provision per the Change Order 01.

**CHANGE IN CONTRACT PRICE:**

**CHANGE IN CONTRACT TIMES:**

Original Contract Price:  
  
\$191,950.00

Original Contract Times:  Working days  Calendar days  
Substantial completion (days or **date**): November 21, 2025 and June 15, 2026  
Ready for final payment (days or **date**): June 30, 2026

[Increase] [Decrease] from previously approved Change Orders No. N/A to No. N/A:  
  
\$0

[Increase] [Decrease] from previously approved Change Orders No. N/A to No. N/A:  
Substantial completion (days): \_\_\_\_\_  
Ready for final payment (days): \_\_\_\_\_

Contract Price prior to this Change Order:  
  
\$191,950.00

Contract Times prior to this Change Order:  
Substantial completion (**date**): November 21, 2025 and June 15, 2026  
Ready for final payment (days or **date**): June 30, 2026

**Increase** of this Change Order:  
  
\$22,250.00

**Increase** of this Change Order:  
Substantial completion (**date**): June 30, 2026  
Ready for final payment (**date**): July 30, 2026

Contract Price incorporating this Change Order:  
  
\$214,200.00

Contract Times with all approved Change Orders:  
Substantial completion (days or **date**): June 30, 2026  
Ready for final payment (days or **date**): July 30, 2026

RECOMMENDED:   
By: \_\_\_\_\_  
Engineer (Authorized Signature)  
Date: April 14, 2026  
Approved by Funding Agency (if applicable): \_\_\_\_\_

ACCEPTED:  
By: \_\_\_\_\_  
Owner (Authorized Signature)  
Date: \_\_\_\_\_

ACCEPTED:  
By: \_\_\_\_\_  
Contractor (Authorized Signature)  
Date: \_\_\_\_\_



**REQUEST FOR LEGISLATION**  
April 17, 2026

FOR Mayor and City Council  
 FROM Joe Meyers, Director of Community Services  
 SUBJECT Building Services Contract

**SUMMARY & BACKGROUND:**

On May 1, 2024, the City entered into an agreement with Carlisle|Wortman Associates, Inc. (CWA) to provide building official co-employment, building inspection, trade inspection, and commercial plan review services for the Building Department. That arrangement has performed well and the City has had no issues with the quality of services provided.

The current agreement expires and staff is recommending renewal for a two-year term from execution through April 30, 2028. The new contract reflects updated rates for 2026/27 and 2027/28 and maintains the same core structure: CWA provides inspectors and plan reviewers as independent contractors, with the City's Building Official managing day-to-day department operations. The building official co-employment component included in the original agreement is not included in this renewal, as the City employs a qualified Building Official.

Service	2026/27 Rate	2027/28 Rate
Commercial Plan Review	\$143/hr	\$150/hr
Building Inspection	\$83/inspection	\$87/inspection
Trade Inspection	\$85/inspection	\$89/inspection
Principal (meetings/court/special)	\$145/hr	\$150/hr

The agreement runs through April 30, 2028, with an option for a mutually agreed third year. Either party may terminate with 60 days written notice. CWA carries \$2,000,000 professional liability and commercial general liability insurance. All work product remains the property of the City.

Recommended Action: Approve a Building Department Consulting Services Agreement with Carlisle/Wortman Associates, Inc. for building inspection, trade inspection, and commercial plan review services for the term through April 30, 2028, to be approved as to form by the City Attorney and signed by the City Manager.

ATTACHMENTS – Carlisle/Wortman Contract

CITY MANAGER APPROVAL

COUNCIL AGENDA DATE

MANAGER COMMENTS –

---

FISCAL SERVICES DIRECTOR APPROVAL

---



**RESOLVED BY THE COUNCIL OF THE CITY OF YPSILANTI:**

WHEREAS the City of Ypsilanti operates a Building Department for the issuance of building permits, inspections, and plan review through the City; and

WHEREAS Carlisle/Wortman Associates, Inc. has provided building inspection, trade inspection, and commercial plan review services to the City since May 1, 2024, and the City has had no issues with the quality of services provided; and

WHEREAS the City employs a qualified Building Official who manages Building Department operations; and

WHEREAS staff recommends renewal of the consulting services agreement for inspection and plan review services through April 30, 2028, at the rates set forth in the proposed agreement;

NOW THEREFORE BE IT RESOLVED that the Ypsilanti City Council approves a Building Department Consulting Services Agreement with Carlisle/Wortman Associates, Inc. for building inspection, trade inspection, and commercial plan review services, for the term through April 30, 2028, to be approved as to form by the City Attorney and signed by the City Manager.

OFFERED BY

---

SUPPORTED BY

---

YES:

NO:

ABSENT:

VOTE:

---



**Carlisle | Wortman**  
ASSOCIATES, INC.

117 NORTH FIRST STREET SUITE 70 ANN ARBOR, MI 48104 734.662.2200 734.662.1935 FAX

**AGREEMENT FOR BUILDING DEPARTMENT CONSULTING SERVICES**

**THIS AGREEMENT**, Entered into this \_\_\_\_\_ day of \_\_\_\_\_ 2026, by **City of Ypsilanti**, hereinafter referred to as the “**Client**” and **Carlisle | Wortman Associates, Inc. (CWA)**, hereinafter referred to as the “**Consultant**.”

**WHEREAS**, the Client has the responsibility under Michigan laws and City ordinances to administer and enforce certain state construction codes and City building, zoning, and land use ordinances in the City.

**WHEREAS**, for purposes of carrying out such responsibilities, Client and CWA desire to coordinate with each other on the co-employment of a building official to administer and enforce construction codes in Ypsilanti City and manage building department services, and to also have CWA provide building and trade inspector and building plan review services on behalf of the Client.

**NOW, THEREFORE**, in consideration of the foregoing, and of the mutual agreement hereinafter set forth, the parties hereto legally intending to be bound hereby do agree for themselves and their respective successors and assigns as follows:

**SECTION 1.0 - SCOPE OF SERVICES**

- 1.1 The Consultant agrees to provide the services described in and in accordance with the items listed in **Exhibit A - Scope of Services** attached hereto and other provisions of this Agreement.
- 1.2 CWA and the Client agree that, in connection with the services provided under this Agreement, they and their employees must at all times adhere to and comply with conflict of interest principles that have been adopted by the Client, if any, or enacted under Michigan law, as required by subsection 9(2) of the State Construction Code Act (MCL 125.1509(2)), as may be amended from time to time, and including the Public Servants’ Conflict of Interest Act, 1868 PA 317, MCL 15.321 through 15.330 (the “Conflict of Interest Act”). In furtherance of ensuring compliance with conflicts of interest principals that are applicable to public employees in the performance of public services, CWA and the Client agree to all of the following:
  - 1.2.1 Building/Trade Inspectors, and plan reviewers performing services under this Agreement may not use their official power to further their own interest and shall not be put into or permitted to place themselves in a position that will subject

*Benjamin R. Carlisle, President John L. Enos, Vice President Douglas J. Lewan, Principal  
David Scurto, Principal Sally M. Elmiger, Principal R. Donald Wortman, Principal Craig Strong, Principal  
Paul Montagno, Principal Megan Masson-Minock, Principal Laura Kreps, Principal Brent Strong, Principal  
Richard K. Carlisle, Past President/Senior Principal*

them to private interests or duties that conflict with their public duties, or cause them to act or be tempted to act in any manner other than the best interests of the public.

1.2.2 Building/Trade Inspectors', and plan reviewers' compensation and benefits package shall not be in any way connected to or dependent on the number of permits issued, inspections performed, plans reviewed, fees collected, or amount of time expended in connection with the services provided under this Agreement.

1.2.3 Building/Trade Inspectors, and plan reviewers performing services under this Agreement: (A) have not solicited (directly or indirectly) this Agreement; (B) have not represented any party in the negotiation of this Agreement; (C) have not taken part and will not take part in the negotiation, renegotiation, amendment, or approval of this Agreement; (D) are not and shall not be parties (directly or indirectly) to this Agreement; (E) have not and shall not be awarded any additional compensation or benefits as a result of the Parties entering into this Agreement; and (F) are not and will not have their employment made contingent or dependent on this transaction or this Agreement being in effect.

1.3 The Client shall provide copies and amendments of the City Code of Ordinances, street maps, and other relevant code books or materials to CWA. These materials shall remain the property of the Client and shall be returned to the Client at the termination of this Agreement upon request.

## **SECTION 2.0**

## **REPRESENTATION**

It is understood and agreed that **Benjamin Carlisle and Brent Strong** will represent the Consultant and the **Community Development Director or other individual designated by the City Council** will represent the Client in all matters pertaining to this Agreement. From time to time, the Consultant may use additional personnel within the firm or sub-consultants to assist in the execution of matters pertaining to this contract. Unless prior approval is granted by the Client the additional personnel or sub-consultants will not be charged to The Client.

## **SECTION 3.0**

## **PAYMENT FOR SERVICES**

**3.1** For services described under this Agreement and Exhibit A - Scope of Services, the Consultant shall be paid in accordance with the rate schedule and fees listed in **Exhibit B - Rates & Fees** attached hereto.

**3.2 Terms of Payment** - The Consultant shall present the Client an invoice each month based on work performed in the previous month. Invoices shall be paid within forty-five (45) days after receipt by the Client.

**SECTION 4.0****CLIENT RESPONSIBILITY**

- 4.1 The Client shall provide the Consultant with authorized access to the Client's offices, network, and software during regular business hours to facilitate the scope of work and records management.
- 4.2 The Client shall provide the Consultant with a report each calendar month listing the building inspections performed by the Consultant for invoicing purposes. The report will be generated from the Client's official permit recordkeeping BS&A software program.

**SECTION 5.0****OWNERSHIP OF MATERIALS**

- 5.1 Any work product, materials, and documents produced by the Consultant pursuant to this Agreement shall be and remain property of the Client and shall not be made subject to any copyright unless authorized by the Client. The Consultant hereby assigns to the Client the copyright to all works prepared, developed, or created pursuant to the services outlined in this Agreement, including the rights to: (1) reproduce the work; (2) prepare derivative works; (3) distribute copies to the public by sale, rental, lease, or lending; (4) perform the works publicly; and (5) to display the work publicly. The Consultant waives its right to claim authorship of the works, to prevent its name from being used in connection with the works, and to prevent distortion of the works.
- 5.2 The Consultant shall provide specific information requested by the Client for response to FOIA requests by the date and time requested by the Client's Clerk or in a specific format if so requested by the Client's Clerk.
- 5.3 If the Consultant receives a claim for damages, a summons or complaint, a subpoena or other document concerning a request for money damages, a threat of a lawsuit, or any court action proceeding, the Consultant shall immediately hand deliver these documents to the Client's Clerk and provide such documents to its errors and omissions insurance carrier.
- 5.4 In the event of litigation, the Client acknowledges that the Consultant can only produce information or materials requested at any point in the litigation process with authorization from the Client's Attorney or designated Legal Counsel. The Client agrees to defend the Consultant against any and all claims when the Consultant is operating under the direction of the Client's Attorney, or other designated Legal Counsel.

**SECTION 6.0****INSURANCE AND LIMITATION OF LIABILITY**

- 6.1 During the term of this agreement, the Consultant agrees to procure and maintain in effect insurance policies in the amounts and with the types of coverage shown below:

1. Professional liability insurance protecting the Consultant and its employees in an amount not less than \$2,000,000.
2. Workers Compensation Insurance in the form and amount required by Michigan law.
3. Commercial General Liability Insurance on an "Occurrence Basis" with limits of liability not less than \$2,000,000 per occurrence and/or aggregate combined single limit, Personal Injury, Bodily Injury and Property Damage.

**6.2** The Client and the Consultant shall have no liability to each other for any claim relating to this agreement in excess of the fees and expenses paid to the Consultant except pursuant to indemnification obligations under Section 7.0. In no event shall the Client and the Consultant be liable to each other for indirect, special, incidental, or consequential damages, even if the Client and the Consultant have been advised of the possibility of such damages. Except as otherwise specifically provided in this agreement, neither party's liability to the other party under this Agreement shall exceed the total amounts paid or payable by the Client under this agreement.

---

**SECTION 7.0****INDEMNIFICATION**

The Consultant agrees, to the fullest extent permitted by law, to indemnify and hold the Client harmless from damages and losses arising from the negligent acts, errors or omissions of the Consultant in the performance of professional services under this Agreement, to the extent that the Consultant is responsible for such damages and losses on a comparative basis of fault and responsibility between the Consultant and the Client. The Consultant is not obligated to indemnify the Client for the Client's own negligence.

---

**SECTION 8.0****TERMS OF AGREEMENT**

- 8.1** The term of this Agreement shall be from the **date this agreement is first executed** through **April 30, 2028**. The contract may be extended for a third year if mutually agreed upon by the Client and Consultant. All rates and fees contained in this Agreement shall increase five percent (5%) if this agreement is extended with no mutually agreed upon rate adjustment.
- 8.2** This Agreement may be terminated by either the Client or Consultant individually or jointly upon **sixty (60) days written notice**. Compensation during the notice period would be paid by the Client to the Consultant if services are faithfully rendered to the Client.

---

**SECTION 9.0****GENERAL PROVISIONS**

- 9.1** The Exhibits attached to and referenced in this Agreement are incorporated into this Agreement by reference and expressly made an integral and component part of this Agreement for all purposes and shall be binding upon the Parties. References to any Exhibit in this Agreement shall be deemed to include this reference and incorporation.
- 9.2** Any notice under this Agreement shall be addressed and directed to the representatives of the Parties identified in Section 2.0.
- 9.3** The headings contained in this Agreement are for convenience in reference and are not intended to define or limit the scope of any provision of this Agreement.
- 9.4** This Agreement is intended solely for the mutual benefit of the Parties hereto, and there is no intention, expressed or otherwise, to create any rights or interest for any party or person other than the Parties.
- 9.5** CWA shall perform the services under this Agreement as an independent contractor and shall not be deemed by virtue of this Agreement to have entered into any partnership, joint venture, employer/employee or other relationship with the Client other than as a contracting party and independent contractor. Except for the Building Official, employees of CWA shall not be deemed to be employees of the City for purposes of compensation, fringe benefits, workers' compensation, unemployment compensation, minimum wage laws, income tax withholding, social security, or any other purpose.
- 9.6** CWA will not discriminate against any employee or applicant for employment because of race, color, religion, sex or national origin. CWA will take affirmative action to ensure applicants are employed, and employees are treated during employment without regard to their race, color, religion, sex or national origin. Such action shall include, but not be limited to the following: employment, upgrading, demotion or transfer; recruitment or recruitment advertising; layoff or termination; rates of pay or other forms of compensation; and selection for training, including apprenticeship.
- 9.7** Nothing in this Agreement shall be construed to waive, limit, or otherwise modify any governmental immunity that may be available by law to the City, its officials, employees, contractors, agents, volunteers, or any other person acting on behalf of the City and, in particular, governmental immunity afforded or available pursuant to the Michigan Governmental Immunity Act, MCL 691.1401, *et. seq.*
- 9.8** This Agreement constitutes the entire agreement between the Parties, and all prior discussion, agreements and understandings, whether verbal or in writing, are merged into this Agreement.
- 9.9** If any section, subsection, clause, phrase or portion of this Agreement is for any reason held invalid, unlawful, or unconstitutional by any court of competent jurisdiction, that portion shall be considered a separate, distinct and independent portion of this

Agreement, and the remaining portions of this Agreement shall remain in full force and effect.

**IN WITNESS WHEREOF**, The Consultant and the Client execute this Agreement as of the date first set forth in this Agreement.

**WITNESSES**

---

---

**CLIENT**

---

**Andrew Hellenga, City Manager**  
Ypsilanti City

---

**CONSULTANT**

---

---

**Benjamin R. Carlisle, AICP**  
President  
Carlisle/Wortman Associates, Inc.

## EXHIBIT A SCOPE OF SERVICES

- 1) The Consultant agrees to provide building consultation services in connection with the scope of work as described below. The Client retains the right to make changes within the general scope of the agreement at any time by a written order. If the changes add to or deduct from the extent of the services, the contract sum shall be adjusted accordingly. All such changes shall be executed under the conditions of the original agreement.
- 2) Quality of Services under this agreement shall be of the level of professional quality performed by experts regularly rendering this type of service. The Consultant shall perform its Services in compliance with all applicable laws, ordinances, standards, and regulations.
- 3) The Consultant's access to the Client's offices shall be limited to the normal business hours of the Client except under circumstances with prior permission granted by the Community Development Director or designee. Consultant shall provide management oversight of individuals assigned to work for the Client and shall cooperate with the Community Development Director or designee to ensure the quality of services provided meets the Client's satisfaction.
- 4) The Consultant agrees to provide individuals registered by the State of Michigan to act as the Client's **Building Inspectors** to perform building permit inspections and reinspections on a regularly scheduled basis. The assigned individuals shall report to the Building Official, shall coordinate work schedules and reporting of inspection results with the Client's Building Department Administrator, shall receive phone calls and answer administrative and technical questions, and shall meet with citizens or permit applicants to answer questions as needed during scheduled work hours.
- 5) The Consultant agrees to provide individuals registered by the State of Michigan to act as the Client's **Trade Inspectors** to perform trade permit inspections and reinspections on an as needed basis. The assigned individuals shall report to the Building Official, shall coordinate work schedules and reporting of inspection results with the Client's Building Department Administrator, shall receive phone calls and answer administrative and technical questions, and shall meet with citizens or permit applicants to answer questions as needed during scheduled work hours.
- 6) The Consultant agrees to perform **Construction Plan Review** for all applicable codes and trades for code compliance. Plan review will be performed by qualified individuals registered by the State of Michigan in all applicable code disciplines. Plan review will be performed in office and remotely and review reports will be submitted in digital format by email. Typical plan review will be completed within 5 business days with larger commercial, multiple, or industrial projects being completed within 10 business days. In cases where this is not possible, applicants will be notified with an explanation and an estimated completion date.

**EXHIBIT B  
RATES AND FEES**

**Commercial Plan Review Services**

Commercial Plan Review Services shall be billed at the hourly rates depicted below for building, mechanical, electrical, plumbing, and fire suppression plan review services. Residential plan review will be performed

<b>2026/27</b>	<b>2027/28</b>
<b>\$143/hr</b>	<b>\$150/hr</b>

**Trade Inspection Services**

Trade Inspection Services shall be performed on an as needed basis. Trade inspections will be billed at per-inspection rates as depicted below.

<b>2026/27</b>	<b>2027/28</b>
<b>\$85/inspection</b>	<b>\$89/inspection</b>

**Building Inspection Services**

Building Inspection Services shall be performed on days and times that the Client and Consultant mutually agree to for the timely performance of building inspections, which may change from time to time. Building inspections will be billed at per-inspection rates as depicted below.

<b>2026/27</b>	<b>2027/28</b>
<b>\$83/inspection</b>	<b>\$87/inspection</b>

Expedited or emergency inspections requested to be performed outside of regularly scheduled business hours shall be billed at a per-inspection rate to be agreed upon by the parties in advance of commencing work.

**Miscellaneous Meetings, Court, Special Projects, Other**

Attendance at meetings requested by the Client outside of regularly scheduled business hours, appearances to testify in court on behalf of the Client, special projects, and other necessary work shall be billed at the hourly rates listed below:

	<b>2026/27</b>	<b>2027/28</b>
<b>Principal</b>	\$145	\$150
<b>Division Director</b>	\$130	\$135
<b>Operations Manager</b>	\$125	\$130
<b>Building Official/Inspector</b>	\$95	\$100
<b>Support Staff</b>	\$80	\$85

Expenses for major projects will be quoted separately upon request. Rates adjust on May 1<sup>st</sup> of every year.

## Building Inspection Cost Analysis — City of Ypsilanti / Carlisle|W

Contract Year	Inspections	Rate / Inspection	Annual Cost
Year 1 (May 2024 – Apr 2025)	795	\$75	\$59,625
Year 2 (May 2025 – Apr 2026)	818	\$79	\$64,622
Year 3 (May 2026 – Apr 2027)	806	\$83	\$66,898
Year 4 (May 2027 – Apr 2028)	806	\$87	\$70,122
<b>TOTAL (All 4 Years)</b>	<b>3225</b>		<b>\$261,267</b>

*\* April 2026 data runs through April 8 only (22 inspections). Full month projected at 82 inspections based on daily based on 2-year average of 806 inspections/year.*

Year-over-Year Comparison			
	Year 1	Year 2	Year 3 (proj)
Inspections	795	818	806
Rate/Inspection	\$75	\$79	\$83
Annual Cost	\$59,625	\$64,622	\$66,898

<b>Vortman Associates</b>	
<b>Notes</b>	
Actual	
Actual (Apr 2026 projected*)	
Projected — new contract rate	
Projected — new contract rate	

*ly rate. Year 3 & 4 inspection volumes*

<b>Year 4 (proj)</b>	
	806
	\$87
	\$70,122

### Monthly Inspection Detail — Actual Data

Month	Inspections	Rate / Inspection	Monthly Cost
2024-05	86	\$75	\$6,450
2024-06	69	\$75	\$5,175
2024-07	75	\$75	\$5,625
2024-08	65	\$75	\$4,875
2024-09	69	\$75	\$5,175
2024-10	84	\$75	\$6,300
2024-11	76	\$75	\$5,700
2024-12	39	\$75	\$2,925
2025-01	39	\$75	\$2,925
2025-02	42	\$75	\$3,150
2025-03	74	\$75	\$5,550
2025-04	77	\$75	\$5,775
2025-05	81	\$79	\$6,399
2025-06	42	\$79	\$3,318
2025-07	74	\$79	\$5,846
2025-08	66	\$79	\$5,214
2025-09	78	\$79	\$6,162
2025-10	71	\$79	\$5,609
2025-11	74	\$79	\$5,846
2025-12	52	\$79	\$4,108
2026-01	73	\$79	\$5,767
2026-02	62	\$79	\$4,898
2026-03	63	\$79	\$4,977
2026-04	22	\$79	\$1,738

<b>Year 1 Subtotal</b>	<b>795</b>	<b>\$75</b>	<b>\$59,625</b>
<b>Year 2 Subtotal</b>	<b>758</b>	<b>\$79</b>	<b>\$59,882</b>





REQUEST FOR LEGISLATION  
April 21, 2026

For: Mayor and City Council

From: Council Member McLean and Mayor Pro-Tem Wilcoxon

Subject: Cruise Night MOU

---

SUMMARY & BACKGROUND:

The Depot Town Cruise Night has been a staple event in the Depot Town District for decades. The event is open to all public and increases the economic vitality of the district.

This is a community run event that attracts people from neighboring communities allowing the region to enjoy this community and all it has to offer.

RECOMMENDED ACTION: Approval

ATTACHMENTS: Resolution and MOU

---

CITY MANAGER APPROVAL: \_\_\_\_\_ COUNCIL AGENDA DATE: \_\_\_\_\_

CITY MANAGER COMMENTS: \_\_\_\_\_

FISCAL SERVICES DIRECTOR APPROVAL: \_\_\_\_\_

BUDGET PRIORITY REFERENCE \_\_\_\_\_



**RESOLVED BY THE COUNCIL OF THE CITY OF YPSILANTI:**

WHEREAS, The Depot Town Cruise Night is an event that has occurred every summer for over thirty-years; and

WHEREAS, the event is open to the public without charge; and

WHEREAS, Depot Town businesses see economic benefit from the event.

NOW THEREFORE BE IT RESOLVED THAT the City Council of the City of Ypsilanti approve the MOU with the Depot Town Economic Development Corporation to hold a Cruise Night on Thursday nights between the beginning of June until the end of September for a period of three-years.

OFFERED BY: \_\_\_\_\_

SUPPORTED BY: \_\_\_\_\_

YES:                      NO:                      ABSENT:                      VOTE:

**MEMORANDUM OF UNDERSTANDING (MOU)**  
**BETWEEN**  
**City of Ypsilanti Ypsilanti, Michigan**  
**AND**  
**Ypsilanti Cruise Night Ypsilanti, Michigan**

DATE: April 21, 2026

**I. PURPOSE**

This Memorandum of Understanding (MOU) delineates the terms and conditions under which the City of Ypsilanti grants permission to Ypsilanti Cruise Night to utilize Cross Street in Depot Town for the conduct of its events.

**II. BACKGROUND**

Ypsilanti Cruise Night is a community-oriented event designed to celebrate classic automobiles and promote community engagement. This event attracts participants and spectators from surrounding areas, thereby fostering local business growth and enhancing community spirit.

**III. TERM**

This MOU shall commence on June 4, 2026, and shall remain in effect until September 30, 2028. The operator shall submit a detailed scope of operations by April of each preceding cruise night season. Any proposed changes to the scope must not incur additional costs to the City.

**IV. SCOPE OF USE**

1. Location: Cross Street in Depot Town, Ypsilanti, Michigan.
2. Event Dates: Thursday nights commencing June 4, 2026, through September 24, 2026.
3. Event Time: 4:00 PM to 9:00 PM.

**V. RESPONSIBILITIES**

**A. City of Ypsilanti**

1. Permit Approval: The City shall issue all necessary permits for the use of Cross Street.
2. Public Safety: The City shall collaborate with local law enforcement and emergency services to ensure the safety of participants and attendees.
3. Maintenance: The City shall ensure that the area is clean and accessible prior to and following each event.
4. Liabilities: The City shall not be responsible for:

- Any requests for assistance from the Department of Public Works, or other departments, outside of regular business hours.
- Any expenses incurred for subcontractors solicited by the operators of Ypsilanti Cruise Night.

#### B. Ypsilanti Cruise Night

1. **Event Coordination:** Ypsilanti Cruise Night shall be responsible for the overall coordination of the event, including logistics, setup, and teardown. All costs incurred by the City of Ypsilanti for cleanup or property damage shall be billed to the Depot Town Community Development Corporation (CDC).
2. **Insurance:** Ypsilanti Cruise Night shall provide proof of liability insurance to cover the event.
3. **Compliance:** Ypsilanti Cruise Night shall comply with all applicable local laws and regulations during the event and remain current in payment of fees assessed by the City in fulfillment of its obligations hereunder.

#### VI. INDEMNIFICATION

Ypsilanti Cruise Night agrees to indemnify and hold harmless the City from any claims, damages, or liabilities arising from the event(s).

#### VII. AMENDMENTS

This MOU may be amended only through mutual written consent of both parties.

#### VIII. TERMINATION

Either party may terminate this MOU with a written notice of at least 30 days to the other party. Additionally, termination may occur if accrued fees from the preceding year remain unpaid by December 1st.

Remainder of the page left intentionally blank

IX. SIGNATURES

This MOU is executed as agreed by the undersigned representatives of the City of Ypsilanti and Depot Town CDC.

City of Ypsilanti

---

Nicole Brown, Mayor

---

Tracey Boudreau, City Clerk

Depot Town CDC

---

[Name] [Title] [Date]



**RESOLVED BY THE COUNCIL OF THE CITY OF YPSILANTI:**

Whereas, the City Council of the City of Ypsilanti recognizes that pollinators are integral to pollination and survival of a diverse array of plant life, including both ornamental and utilitarian plants;

Whereas, pollinator populations and water resources are threatened due to habitat loss, pathogens, parasites, and irresponsible use of pesticides;

Whereas, research suggests that bees and other pollinators make use of less-intensively maintained lawn spaces;

Whereas, reduced frequency of mowing has been shown to have direct and indirect benefits to pollinator species;

Whereas, the City of Ypsilanti is committed to its designation as Bee City, the mission of BEE CITY USA is to galvanize communities to sustain pollinators, responsible for the reproduction of almost 90% of the world's flowering plant species, by providing them with healthy habitat, rich in a variety of native plants and free to nearly free of pesticides;

THEREFORE BE IT RESOLVED, that the City Manager shall encourage property owners to reduce mowing frequency and to maintain lawn heights between 6 and 12 inches on their properties during the months of April and May, and to mow lawns no lower than 3 inches throughout the year;

RESOLVED, that City Manager shall encourage property owners to mulch grass clippings and leaves into their lawns in lieu of using pesticides and fertilizers where appropriate;

RESOLVED, that the City Manager shall direct staff to not issue correction notices for long grass and weed violations under twelve inches for the month of May, permitting all residents to voluntarily delay lawn care until June, allowing pollinator species to emerge and early flowering grasses and flowers to establish, which may result in ground-cover exceeding established ordinance height restrictions;

RESOLVED, that the Sustainability Commission study and recommend policies for City Council to consider that would promote pollinator health across the whole year;

RESOLVED, that the City Manager shall instruct the Department of Public Services to mow city owned lawns and properties no lower than 3 inches throughout the year.

OFFERED BY: \_\_\_\_\_

SUPPORTED BY: \_\_\_\_\_

YES:

NO:

ABSENT:

VOTE:



**RESOLVED BY THE COUNCIL OF THE CITY OF YPSILANTI:**

WHEREAS, on April 28th, 1971, the Occupational Safety and Health Act (OSHA) went into effect, promising every worker the right to a safe job, and

WHEREAS, every year on April 28th, communities and worksites around the world honor friends, family members, and colleagues who have been killed or injured on the job; and

WHEREAS, the U.S. Department of Labor, and the Federal Bureau of Labor Statistics estimates that Michiganders have died while on the job at an average rate of 147 people per year over the past decade; and

WHEREAS, the 2024 National Census of Fatal Occupational Injuries found a worker died every 99 minutes from a work-related injury; and

WHEREAS, it is appropriate to honor the memory of the courageous and dedicated members of Michigan's labor force who have been injured or disabled or have died as a result of workplace accidents; and

WHEREAS, we remember those who have died in workplace catastrophes, suffered occupational-related diseases, or have been injured due to dangerous conditions; and

WHEREAS, recognition of the integrity of Michigan's workforce and its achievements on behalf of the economic growth of our state is necessary; and

WHEREAS, the City Council of the City of Ypsilanti wishes to pay tribute to the workers who have died or been injured or disabled in workplace accidents. We honor the contributions of Michigan's workforce and call for increased workplace safety; and

WHEREAS, the City Council of the City of Ypsilanti renews our efforts to seek stronger workplace safety and health protections, better standards and enforcement, and fair and just compensation; and by rededicating ourselves to improving safety and health in every city workplace;

NOW, THEREFORE, BE IT RESOLVED that the members of this legislative body declare April 28, 2025, as

**Workers Memorial Day**

in the City of Ypsilanti, Michigan.

OFFERED BY: \_\_\_\_\_

SUPPORTED BY: \_\_\_\_\_

YES:                      NO:                      ABSENT:                      VOTE:



REQUEST FOR LEGISLATION  
April 21, 2026

For: Mayor and City Council

From:

Subject: Discussion regarding Ypsilanti Townships Resolution No. 2026-08 Requesting that the Ypsilanti Community Utilities Authority Impose an Immediate Moratorium on Services to Data Centers

---

SUMMARY & BACKGROUND:

RECOMMENDED ACTION:

ATTACHMENTS:

1. Resolution 2026--08 Requesting that the Ypsilanti Community Utilities Authority Impose an Immediate Moratorium

---

CITY MANAGER APPROVAL:

COUNCIL AGENDA DATE: April 21, 2026

CITY MANAGER COMMENTS:

FISCAL SERVICES DIRECTOR APPROVAL:

# CHARTER TOWNSHIP OF YPSILANTI

## RESOLUTION 2026-08

**A RESOLUTION OF THE YPSILANTI TOWNSHIP BOARD OF TRUSTEES REQUESTING THAT THE YPSILANTI COMMUNITY UTILITIES AUTHORITY IMPOSE AN IMMEDIATE MORATORIUM ON THE DELIVERY, COMMITMENT, RESERVATION, EXTENSION, OR APPROVAL OF WATER AND SEWER SERVICES FOR HYPERSCALE DATA CENTERS, MID-SIZED DATA CENTERS, ARTIFICIAL INTELLIGENCE COMPUTING FACILITIES, AND HIGH-PERFORMANCE COMPUTATIONAL CENTERS PENDING COMPLETION OF COMPREHENSIVE DUE DILLIGENCE INVESTIGATIONS CONSISTENT WITH INDUSTRY BEST PRACTICES, INCLUDING BUT NOT LIMITED TO THE AMERICAN WATERWORKS ASSOCIATION’S RECOMMENDATIONS, AS WELL AS THE WATER ENVIRONMENT FEDERATION, IN RESPONSE TO THE STATE OF MICHIGAN’S DATA CENTER TAX INCENTIVES.**

*WHEREAS*, the Charter Township of Ypsilanti (Township) is charged under its authority as a Charter Township with protecting the public health, safety, and welfare of its residents; and

*WHEREAS*, the Township, along with the City of Ypsilanti are constituent members of the Ypsilanti Community Utilities Authority (YCUA) and rely upon YCUA to provide essential water supply and wastewater treatment services critical to public health, environmental integrity, economic stability, and fire protection; and

**WHEREAS**, YCUA is entrusted with safeguarding the capacity, reliability, and long-term sustainability of the regional water supply and the wastewater treatment systems; and

**WHEREAS**, the American Water Works Association (AWWA) has issued its authoritative White Paper ***“Cooling the Cloud: Water Utilities in a Data-Driven World”*** concluding that hyper-scale data centers, as well as other mid-sized data centers, artificial intelligence computing facilities, and high-performance computational centers are ***“high-impact customers”*** for water and sewer utilities and that these centers increase water and demands, infrastructure strain, and operational costs and, as such, public utilities such as YCUA must undertake proactive planning and coordination before service commitments are made to the aforementioned centers; and

**WHEREAS**, the hyper-scale data centers, mid-sized data centers, artificial intelligence computing facilities, and high-performance computational centers require extraordinary volumes of water for cooling and industrial processes and may consume up to 5 million gallons of water per day, which will require wastewater treatment per each gallon of water, thereby generating significant wastewater discharges associated with cooling systems, chemical treatment, and thermal discharge requiring advanced treatment capacity and regulatory compliance with unique thermal and chemical characteristics; and

**WHEREAS**, the State of Michigan has enacted legislation, including but not limited to amendments to the General Property Tax Act and related statutes, to provide substantial tax incentives for the development of hyper-scale data centers, mid-sized data centers, artificial intelligence computing facilities, and high-performance computational centers, including “**Six Percent sales and use tax exemptions on data center equipment, including servers and related hardware, incentives tied to large-scale capital investments often exceeding hundreds of millions of dollars;**” and

**WHEREAS**, the enactment and expansion of the tax incentive programs were designed to attract large-scale, high-density computational developments to Michigan, including hyper-scale data centers, mid-sized data centers, artificial intelligence computing facilities, and high-performance computational centers, thereby creating a foreseeable and substantial increase in applications for such facilities across Michigan and throughout Washtenaw County, including the communities which receive water and sewer services provided by YCUA; and

**WHEREAS**, these tax incentives approved by the Michigan Legislature and signed into law by Governor Gretchen Whitmer have created an artificially-induced marked demand, which has also resulted in the potential clustering of all of the facilities referenced above in areas of available land, infrastructure, power, and water, including Washtenaw County; and

**WHEREAS**, the Township finds that the State of Michigan's tax incentives have an irreparable and harmful impact upon tax revenues that benefit local governments and schools and do not adequately account for the consumptive use of water resources, along with the required sewer capacity, by the hyper-scale data centers, mid-sized data centers, artificial intelligence computing facilities, and high-performance computational centers, which encourages the development of these centers which could be incompatible with YCUA's long-term water and sewer capacity sustainability; and

**WHEREAS**, the Township finds that these tax incentives approved by the Michigan Legislature and Governor Whitmer have the effect of pressuring public utilities such as YCUA to commit to water and sewer capacity without sufficient time to conduct thorough engineering, environmental, financial, and capacity reviews; and

**WHEREAS**, the Director of YCUA has confirmed that YCUA continues to receive inquiries from representatives of hyper-scale data centers, mid-sized data centers, artificial intelligence computing facilities, and high-performance computational centers regarding YCUA's water and sewer capacity to serve said centers; and

**WHEREAS**, the best practices required to be followed by YCUA, including those promulgated by the AWWA and the WEF, emphasize the necessity of rigorous, science-based due-diligence analyses, **which are to be completed prior to the approval of high-demand, hyper-scale data centers, mid-sized data centers, artificial intelligence computing facilities, and high-performance computational centers;** and

**WHEREAS**, the Township has not been provided with sufficient evidence demonstrating that YCUA's current infrastructure can sustainably meet the high-volume continuous water and sewer demands of hyper-scale data centers, mid-sized data centers, artificial intelligence computing facilities, and high-performance computational centers, which operate 24-hours per day, 365 days per year, nor evidence demonstrating that YCUA can safely treat and discharge the wastewater associated with these facilities without experiencing capacity degradation affecting residential, commercial, and light industrial properties located in the Township and other communities serviced by YCUA; and

**WHEREAS**, the failure to fully evaluate these impacts presents a material risk of the availability of water and sewer capacity to the Township and the City of Ypsilanti, and may alter wastewater composition through chemical treatment processes, which will increase the thermal discharge loads and will require additional treatment beyond YCUA's current design capacity, thereby

resulting in potential regulatory violations and capacity degradation affecting residential, commercial, and light industrial properties; and

**WHEREAS**, the Township finds that proceeding without comprehensive due-diligence studies conducted by YCUA consistent with the standards and recommendations of the AWWA and WEF would be premature, imprudent, and in conflict with the public interest.

**NOW THEREFORE BE IT RESOLVED** that the Charter Township of Ypsilanti Board of Trustees hereby formally requests and urges YCUA to immediately impose a moratorium of not less than 12 months on the delivery, commitment, reservation, extension, or approval of water and sewer services to hyper-scale data centers, mid-sized data centers, artificial intelligence computing facilities, and high-performance computational centers pending completion of comprehensive due diligence investigations consistent with industry best practices, including but not limited to the American Water Works Association's recommendations, as well as the Water Environment Federation.

**BE IT FURTHER RESOLVED** that the moratorium imposed by YCUA as it pertains to the aforementioned centers shall include but not be limited to new service connections, capacity reservations, infrastructure expansion commitments, and preliminary or conditional approvals.

**BE IT FURTHER RESOLVED** that the moratorium shall remain in effect until the completion of the following analyses as recommended by the AWWA and WEF, which shall include but not limited to the following:

**(1) Long-Term Water Supply And Comprehensive Capacity Analysis, Which Shall Include Peak Demand Modeling, Drought And Emergency Resilience;**

**(2) Long-Term Wastewater Treatment And Sewer Capacity Analysis, Which Shall Include Wastewater Treatment Compatibility Studies, Effluent Composition, Temperature Analysis, And YCUA's Thermal Discharge And Water Quality Impact Assessments;**

**(3) Financial And Ratepayer Impact Analysis, Which Shall Also Include Prevention Of Cross-Subsidization Of Required Capital Improvements To Serve The Aforementioned Centers So As To Ensure That No Costs Are Shifted To YCUA's Existing Customers And Ratepayers;**

**(4) Infrastructure and Capital Planning Analysis, Which Shall Include All Required Upgrades And Expansion Costs That Would Be Attributed To Providing Water And Sewer Capacity To The Centers Referenced In This Resolution, Including Infrastructure Stress and Redundancy Analysis, The Costs Of Which Shall Be Borne By Any Center Referenced In This Resolution Seeking Water And Sewer Services From YCUA;**

**(5) Environmental And Sustainability Review;**

**(6) Emergency Response And System Resiliency Assessment;**

**BE IT FURTHER RESOLVED** that the Township requests YCUA to conduct all of the aforementioned studies in a transparent and public process, to engage independent qualified third-party experts where appropriate, which studies shall be subject to peer review and comment, and to provide regular updates to the Township Board and the public on a quarterly basis.

**BE IT FURTHER RESOLVED** that, during the 12-month moratorium period, YCUA shall refrain from executing any capacity reservation agreements, issuing **“Will-Serve Letters or Conditional Approvals”** and making infrastructure commitments that could prejudice the outcome of all of the required due-diligence investigations and studies.

**BE IT FURTHER RESOLVED** that Resolution 2026-08 is supported by authoritative AWWA and WEF guidance and recommendations requiring proactive planning and due diligence by public utilities such as YCUA, as well as documented evidence of extreme water and sewer demand and infrastructure strain by hyper-scale data centers, mid-sized data centers, artificial intelligence computing facilities, and high-performance computational centers.

**BE IT FURTHER RESOLVED** that Resolution 2026-08 is also supported by the State of Michigan's tax benefit incentives to all the aforementioned centers, which has resulted in the acceleration of these planned hyper-scale data centers, mid-sized data centers, artificial intelligence computing facilities, and high-performance computational centers without the appropriate safeguards to the water supply and sewer capacity of YCUA.

**BE IT FURTHER RESOLVED** that Resolution 2026-08 is supported by the Township's authority as a Charter Township, which includes the prevention of irreversible harm to the public infrastructure of YCUA, including but not limited to the water and sewer transmission pipes, collection sewers, interceptor sewers, sanitary force mains, and pump stations.

**BE IT FURTHER RESOLVED** that a certified copy of Resolution 2026-08 be forwarded by the Township Clerk's office to the Mayor for the City of Ypsilanti, and all Ypsilanti City Council Members, Governor Gretchen Whitmer, US Senators Gary Peters and Elissa Slotkin, Congresswoman Debbie Dingell, State Senator Jeff Irwin, State Representative Jimmie Wilson Jr., and the Washtenaw County Board of Commissioners.

**NOW THEREFORE BE IT RESOLVED** that Resolution 2026-08 is hereby adopted.

I, Debra A. Swanson, Clerk of Charter Township of Ypsilanti, County of Washtenaw, State of Michigan, hereby certify the above resolution is a true and exact copy of Resolution No. 2026-08 approved by the Charter Township of Ypsilanti, Board of Trustees assembled at a Special Meeting held on April 15, 2026.



Debra A. Swanson, Clerk  
Charter Township of Ypsilanti



REQUEST FOR LEGISLATION  
April 21, 2026

For: Mayor and City Council

From:

Subject: Discussion Item - Gas Leaf Blower Ban

---

SUMMARY & BACKGROUND:

RECOMMENDED ACTION:

ATTACHMENTS:

---

CITY MANAGER APPROVAL:

COUNCIL AGENDA DATE: April 21, 2026

CITY MANAGER COMMENTS:

FISCAL SERVICES DIRECTOR APPROVAL: